

**120VAC/277VAC
EMERGENCY LED CAST EXIT
SINGLE OR DOUBLE FACE WITH
6 VOLT 11 WATT REMOTE LAMP CAPACITY**

**INSTALLATION AND OPERATING
INSTRUCTIONS**

IMPORTANT SAFEGUARDS

When using electrical equipment, basic safety precautions should always be followed, including the following:

**READ AND FOLLOW ALL
SAFETY INSTRUCTIONS**

All servicing should be performed by qualified personnel only.

Do not use this equipment outdoors.

Do not mount near gas or electric heaters.

Equipment should be mounted in locations and at heights where it will not readily be subjected to tampering by unauthorized personnel.

The use of accessory equipment not recommended by the manufacturer may cause an unsafe condition.

Do not use this equipment for other than intended use.

Do not let power supply cords touch hot surfaces.

Do not mount near open flames or sparks.

Do not install equipment in areas of excessive moisture.

SAVE THESE INSTRUCTIONS

WARNING - Shut off AC power to branch circuits to which units will be connected. All wiring should be per National Electrical Code and local regulations.

To maintain warranty, equipment with batteries must be installed or placed on charge within prescribed period after shipment.

Electrical hookups are to be made inside outlet box. All parts needed to mount the exit are supplied with the exception of wire nuts for AC supply connections.

TOP AND SIDE MOUNT INSTALLATION

1. EXIT FRAME AND PANEL PREPARATION

- A. Door of sign is hinged at the bottom and may be opened by turning a screwdriver in the top near the finger grooves and pulling the door open. (See Figure 1)
- B. Remove Light Chamber Assy.
- C. Chevrons (left, right, or both) may be knocked out with a screwdriver and hammer. Bend back lens and knock out chevron from the **INSIDE** of the door. Support door when removing knockouts to prevent distortion.
- D. With appropriate chevron knockouts removed, peel backing from the double coated tape located around the exit stencil. Carefully install lens and press against tape to secure. (See Figure 2)
- E. Make provisions for assembling canopy to frame by removing top, side or back knockouts as in Note 1C above.
- F. Replace Light Chamber Assy. Dress wires to prevent shadowing.

2. CANOPY INSTALLATION

- A. Assemble canopy to exit frame with nipple and (2) nuts. (See Figure 3 for proper orientation of canopy to exit frame.)
- B. Route white, orange and yellow wires from exit through nipple and close exit door.

3. AC SERVICE HOOKUP

- A. Remove AC supply and remote load connectors from canopy assy.

TOP AND SIDE MOUNT INSTALLATION (CONT.)

- B. Make AC service connections at this time as follows: (See Figure 4)

120V INPUT	277V INPUT
Black wire to line	Blue wire to line
White wire to common	White wire to common
Green wire to ground	Green wire to ground
Yellow/Grey wires to remote load	

Unused primary wire must be insulated to prevent shorting.

- C. Screw backplate to junction box. Reconnect AC supply and remote load connectors to charger assy and attach to backplate. (Figure 5)
- D. Connect four circuit connector from switch assy in canopy to charger assy. Connect white, orange and yellow leads from exit to corresponding color coded connectors from charger assy. Green wire with ring terminal is to be screwed to interior of housing as shown. (Figures 6 & 7)

The supplied hanger may be used to support the exit while making these connections.

- E. Use long screws supplied to screw canopy/exit assy to backplate.

BACK MOUNT INSTALLATION

- A. Follow instructions in section 1 "EXIT FRAME AND PANEL PREP"

- B. Make AC service connections at this time as follows: (See Figure 4)

120V INPUT	277V INPUT
Black wire to line	Blue wire to line
White wire to common	White wire to common
Green wire to ground	Green wire to ground
Yellow/Grey wires to remote load	

Unused primary wire must be insulated to prevent shorting.

- C. Screw backplate to junction box. Reconnect AC supply and remote load connectors to charger assembly and attach to backplate. (See Figure 5)
- D. Connect four circuit connector from canopy assy to charger assy. Insert nipple and one nut into opening in canopy. Pull white, orange and yellow connectors thru nipple and screw canopy to backplate.
- E. Assemble exit frame to canopy with remaining nut. Connect white orange and yellow connectors to corresponding connectors inside exit. Green wire with ring terminal is to be screwed to interior of housing as shown (Figure 7). Dress wires with cable ties to prevent shadowing.

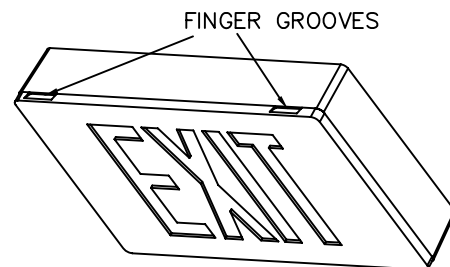

FIGURE 1

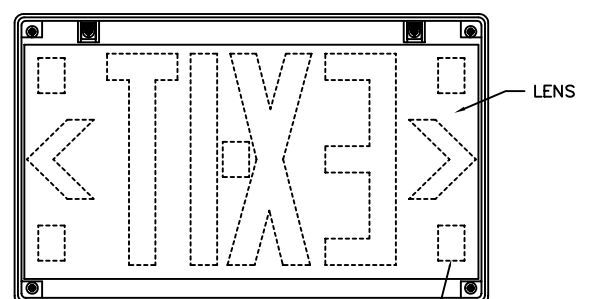
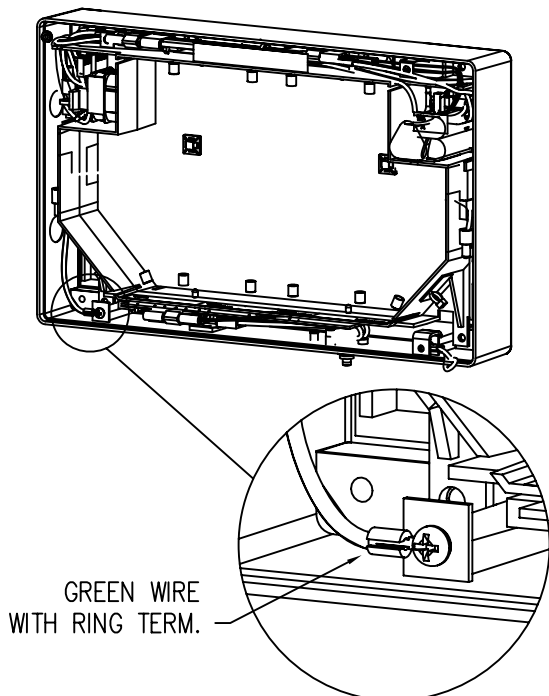
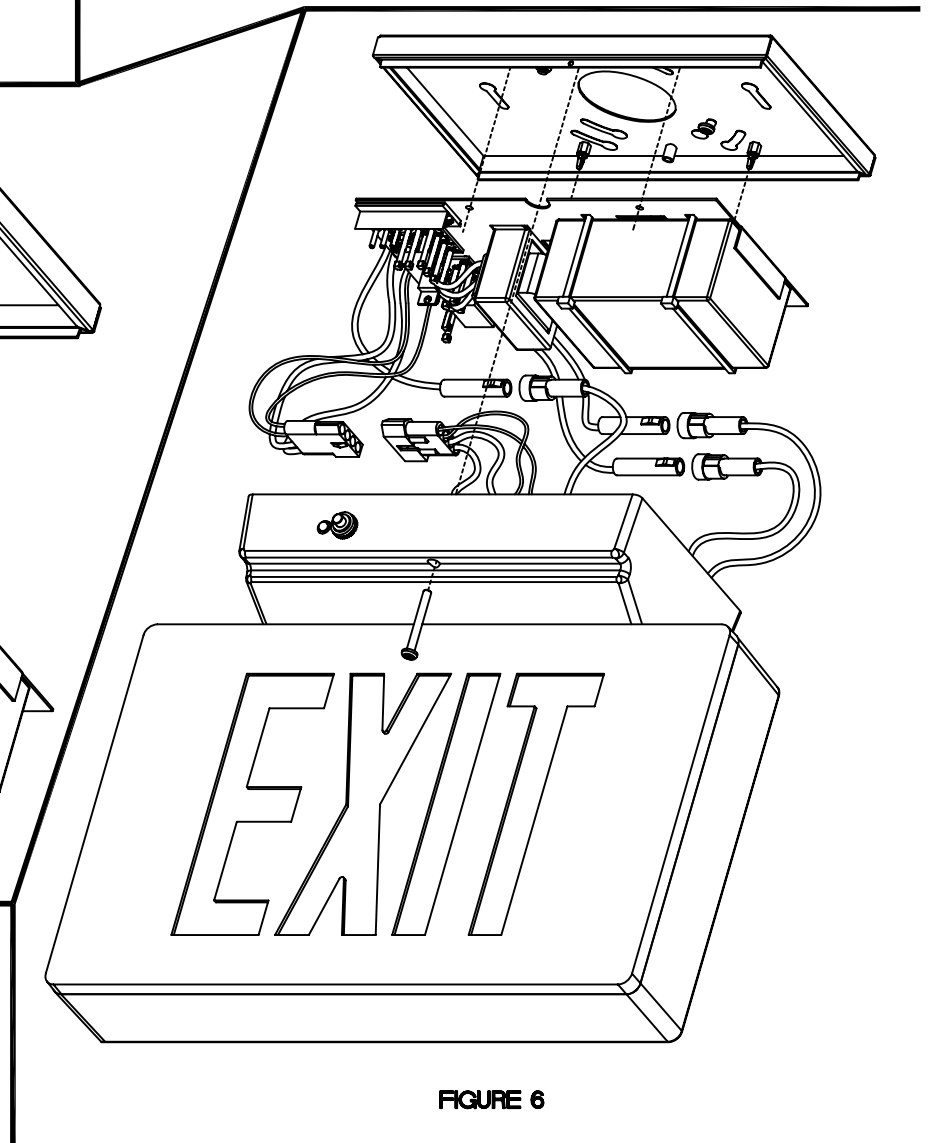
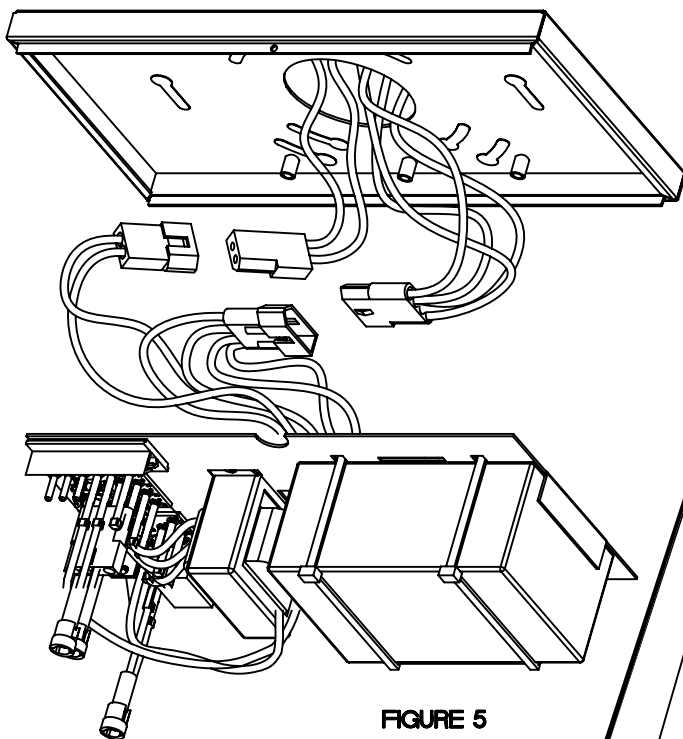
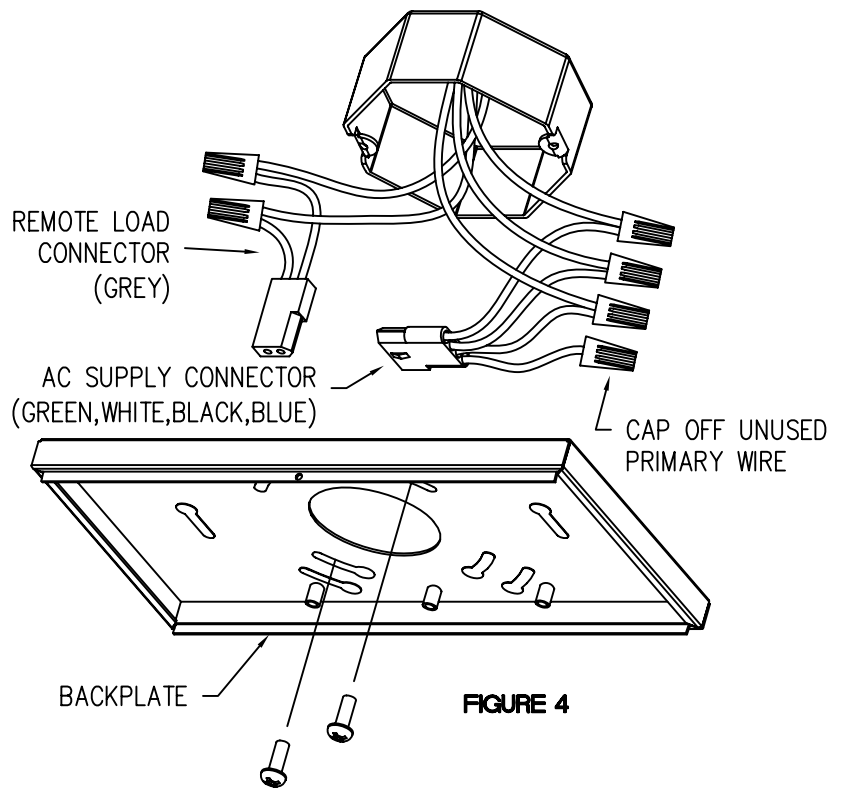
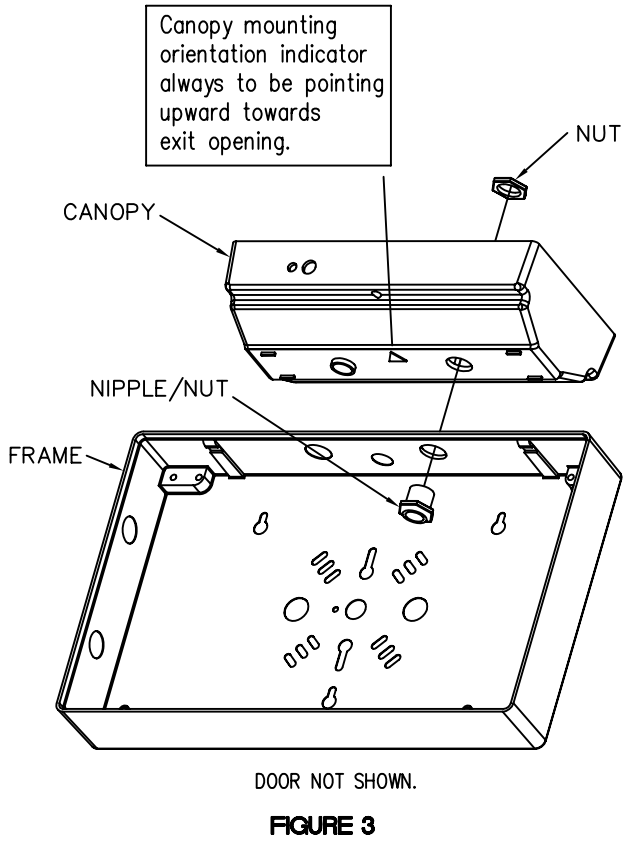

FIGURE 2

CAST LED EXIT W/'RO' OPTION



OPERATION

- A. Energize AC and check that exit is illuminated.
- B. Press test switch and verify that pilot lamp shuts off and exit is illuminated.
- C. Leave AC connected for a minimum of 24 hours before performing any abbreviated testing. Full recharge of batteries may take up to one (1) week.