

CHLORIDE

Fusion3

120VAC OR 277VAC
EMERGENCY OPERATION

Service Questions Call: 910-259-1000

IMPORTANT SAFEGUARDS

When using electrical equipment, basic safety precautions should always be followed, including the following:

READ AND FOLLOW ALL SAFETY INSTRUCTIONS

All servicing should be performed by qualified personnel only.

Equipment should be mounted in locations and at heights where it will not be readily subjected to tampering by unauthorized personnel.

The use of accessory equipment not recommended by the manufacturer may cause an unsafe condition.

Do not use this equipment for other than intended use.

Do not let supply cords touch hot surfaces.

Do not mount near gas or electric heaters.

Caution: Halogen cycle lamp(s) are used in this equipment. To avoid shattering: Do not operate lamp in excess of rated voltage, protect lamp against abrasion and scratches and against liquids when lamp is operating, dispose of lamp with care.

Halogen cycle lamps operate at high temperatures. Do not store or place flammable materials near lamp.

Use caution when servicing batteries. Battery acid can cause burns to skin and eyes. If acid is spilled



INSTALLATION AND OPERATING INSTRUCTIONS

on skin or eyes, flush acid with fresh water and contact a physician immediately.

CAUTION: To avoid electrical overload, total connected lamp load (factory and field installed) should not exceed output rating.

SAVE THESE INSTRUCTIONS

WARNING – Shut off AC power to branch circuits to which units will be connected. All wiring should be per N.E.C. Articles 501-4(b) and local codes.

To maintain warranty, equipment with batteries must be installed or placed on charge within prescribed period after shipment.

GENERAL INSTRUCTIONS

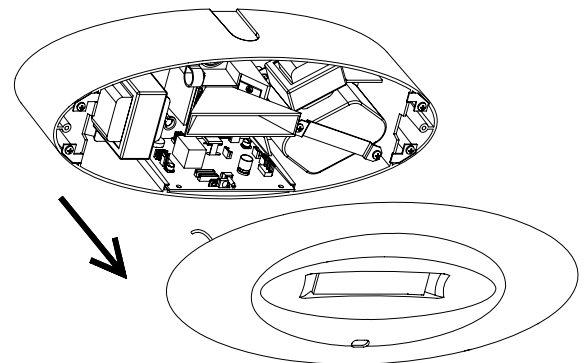

STEP 1

Remove cover assembly by pulling straight off of housing assembly (there are two spring clips that hold them together). Set cover assembly aside.

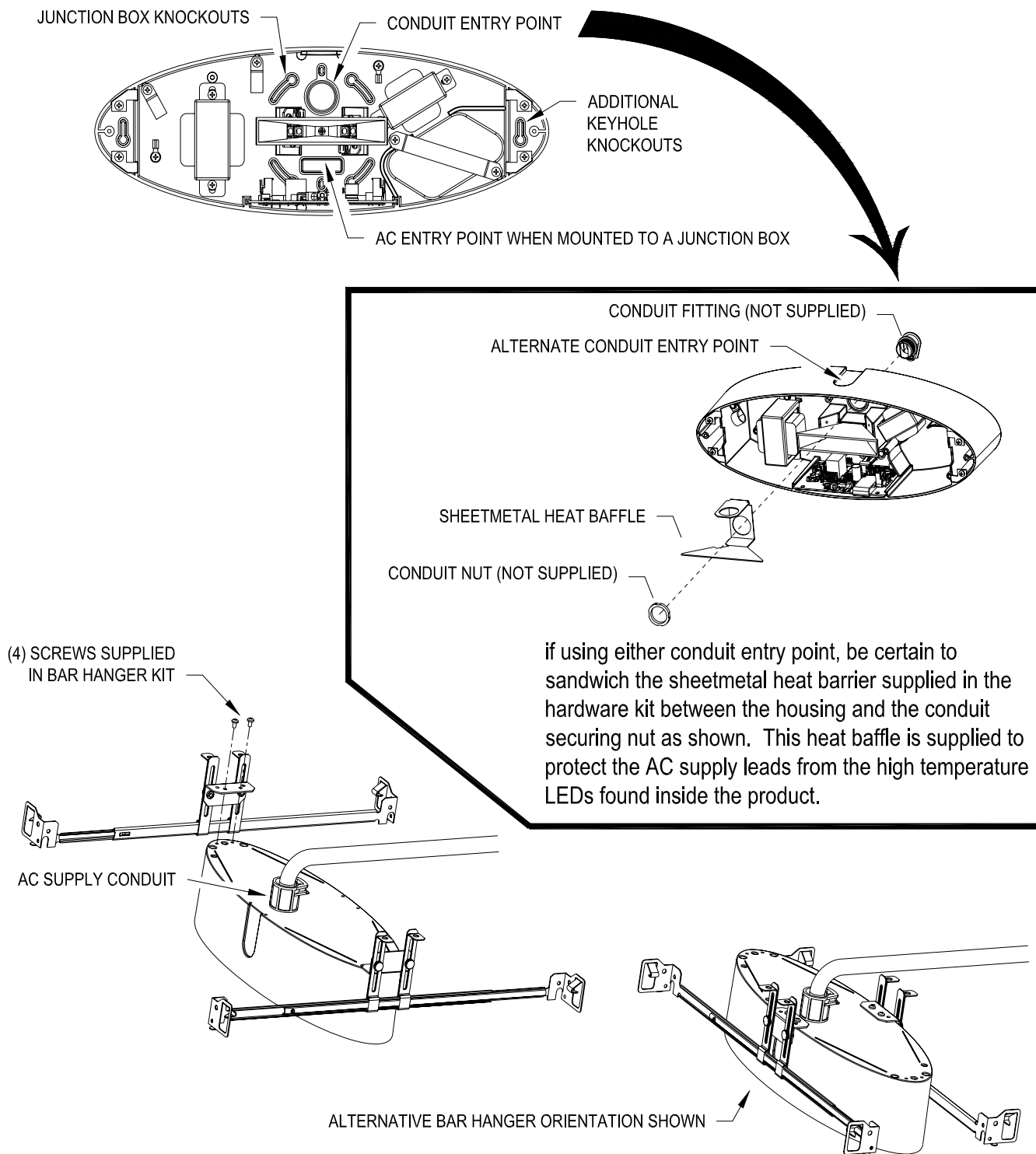

STEP 2

For surface mounting, a knockout pattern is supplied for 3-1/2" octagonal or single gang junction boxes. Remove desired mounting knockouts and the rectangular knockout found in the lower center area of the housing. The rectangular knockout will allow for AC supply entry. (The LED's may be seen to flash while striking the knockouts for removal. The battery may be temporarily disconnected to eliminate this if desired).

For recessed mounting, the packaging insert also functions as a template for cutting the correct size and shape opening in the mounting surface. A bar hanger kit is supplied. The bar hangers may be mounted to the housing assembly in either orientation shown depending upon desired mounting. A round conduit entry knockout is provided in the upper center or side of the housing.

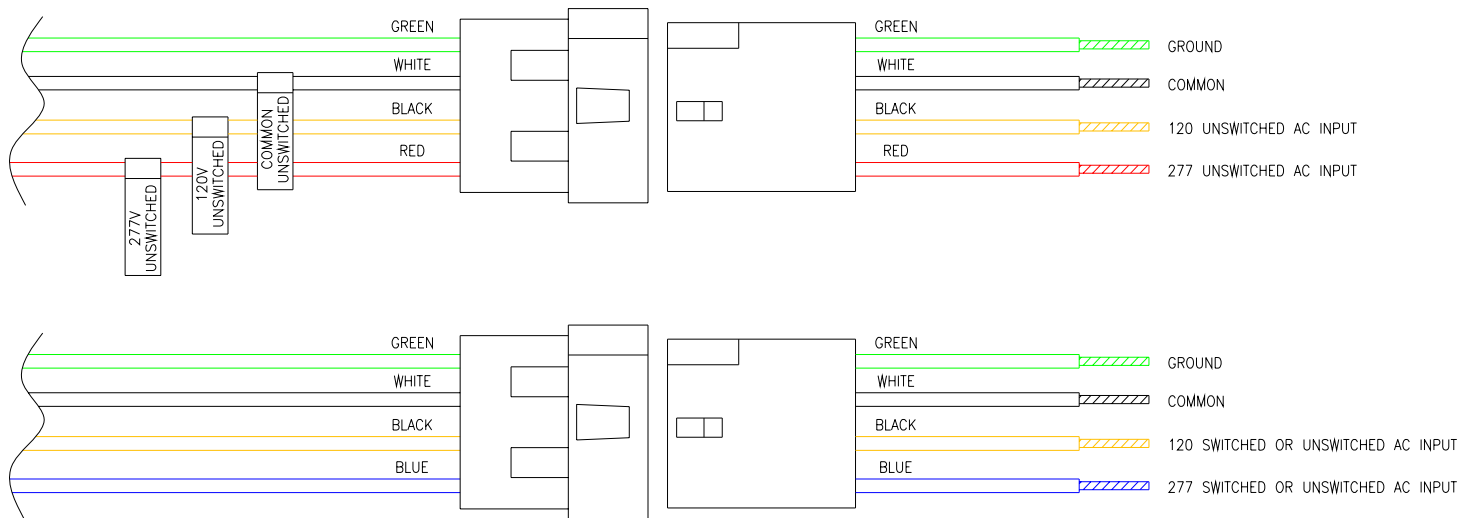

STEP 3

Make AC supply connections. There are two inputs required.

- 1) The connector assembly marked with “unswitched” labels and bearing a red wire must be connected to an unswitched (always hot) input. Cap off unused 120VAC or 277VAC wire to prevent shorting. This input will charge the batteries. Loss of this input will cause the unit to enter emergency operation mode.
- 2) The second input, bearing a blue wire, may be connected to either switched or unswitched AC service. Cap off unused 120VAC or 277VAC wire to prevent shorting. This input controls the operation of the lamps in non-emergency conditions and may be connected to a wall switch, photocell, etc.

Caution: At power up, if red and green LED indicators continuously toggle on and off in an alternating pattern, immediately turn off AC power and check AC wiring per the above diagram. Fast flashing indicates high line voltage and slow flashing indicates low line voltage.

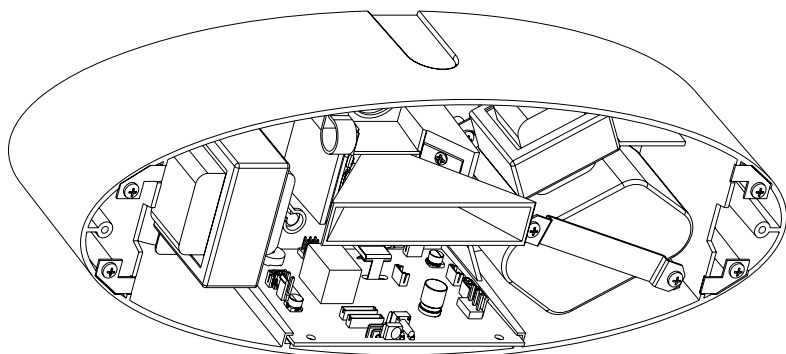

STEP 4

Reinstall cover assembly.

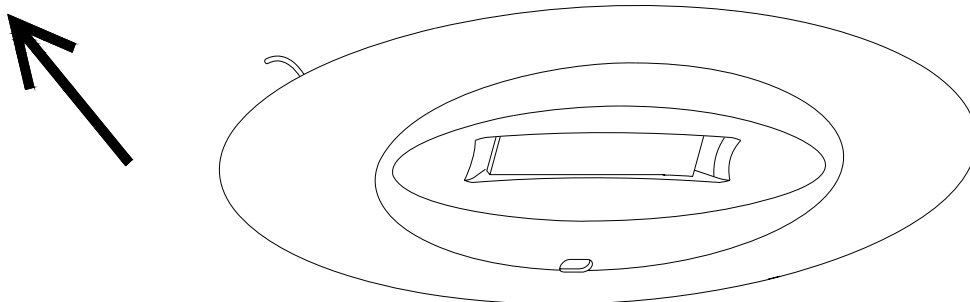

SMART CHARGER SYSTEM OPERATION

(EMERGENCY OPERATION UNITS ONLY)

Normal Power-Up Sequence

At power-up, the red and green LED indicators will alternately flash for one to two seconds. Next, the unit will go through a “Power-Up Quick Test” with the green LED flashing quickly. If no power-up faults were detected, the green LED will then flash slowly for up to 36 hours to indicate that the battery is charging. If any faults were detected during the “Power-Up Quick Test”, these will be indicated by a flashing red LED indicator (see below for interpretation of flashing sequences). The red LED may be accompanied by a buzzer. This buzzer may be disabled by a short press of the test switch or by the “SILENCE ALARM” button on the remote tester and will remain disabled for a period of 196 hours. After the fault has been corrected, the red LED flash and buzzer will be cleared automatically and the unit will return to normal operation except in the case of lamp failure. Once relamping has been completed, perform a manual test to clear the fault.

Emergency Operation

Emergency operation occurs when AC power fails. The unit remains in this mode until AC power is restored. During emergency operation, both red and green LED indicators are disabled. Upon restoration of AC power, the green LED will flash for up to 36 hours to indicate that the unit is in battery charging mode.

User Interface

Green LED Indicator

- Steady On – AC power is present and battery is fully charged
- Slow Flash – Battery charging
- Fast Flash – Unit is performing an automatic or manually initiated self-test

Red LED Indicator

- Single Flash – Battery fault
- Double Flash – Lamp failure
- Triple Flash – Charger fault

(If more than one fault condition is present simultaneously, the red LED will flash each fault pattern in sequence, and then repeat)

Red and Green LED Indicators Together

- Fast flashing red and green – 277VAC applied to 120VAC input lead

Pushbutton Test Switch

- Long Press (over .5 seconds) – Transfers unit to emergency (battery) operation as long as button is depressed
- Short Press – Initiates various self tests
 - One Press – Cancel any self-test currently running
 - Two Presses – Start 1 minute self-test
 - Three Presses – Start 90 minute self-test
 - Seven presses – Forces a complete system reset

(The unit will allow up to seven 1 minute tests during the first 24 hours of operation. Allow at least 24 hours for battery charging before performing and extended amount of testing)

Buzzer – Sounds in unison with the flashing red LED if a fault is detected. May be disabled for up to 196 hours by a short press of the test switch.

IR receiver – Used with the optional hand-held IR remote tester to initiate or cancel manual testing.