

CHLORIDE SYSTEMS

CF750-4PT

Service Questions Call: 910-259-1000

IMPORTANT SAFEGUARDS

When using electrical equipment, basic safety precautions should always be followed, including the following:

READ AND FOLLOW ALL SAFETY INSTRUCTIONS

All servicing should be performed by qualified personnel only.

To prevent Electrical shock, do not connect emergency ballast battery connectors until installation is complete and AC power has been applied.

This product is designed for use in UL listed indoor fixtures only, except for those used in air handling, heated or hazardous locations.

Equipment should be mounted in locations and at heights where it will not be readily subjected to tampering by unauthorized personnel.

Do not use this equipment for other than intended use.

Do not use outdoors.

Do not let supply cords touch hot surfaces.

Do not mount near gas or electric heaters.

Do not install in areas of excessive moisture.

Do not use this equipment for other than its intended use.

Do not attempt to service the battery. Contact manufacturer for information on servicing equipment.

Ensure all power has been removed prior to start of installation.

Install in accordance with National Electrical Code and local code guidelines.

SAVE THESE INSTRUCTIONS

PRODUCT DESCRIPTION

The CF750-4PT Emergency ballast requires an unswitched 120V or 277V AC input and is designed for use with one 13-42W or two 13-39W compact fluorescent lamps. The CF750-4PT provides a minimum of 90 minutes of emergency operation in accordance with UL924 requirements. A momentary test switch, charging indicator light and test/monitor plate are supplied with the CF750-4PT.

The CF750-4PT also has a Time Delay circuit that when used in conjunction with an AC ballast with EOL detection, helps prevent false over voltage and over current detection, by the AC ballast, during the transition from emergency to normal operating mode.

WARNING

**ENSURE ALL AC POWER HAS BEEN REMOVED FROM
FIXTURE BEFORE BEGINNING INSTALLATION**

INSTALLATION

CAUTION: TO PREVENT ELECTRICAL SHOCK, BATTERY CONNECTORS SHOULD NOT BE CONNECTED UNTIL INSTALLATION IS COMPLETE AND AC POWER HAS BEEN APPLIED TO EMERGENCY BALLAST.

1. Install the CF750-4PT emergency ballast (see Illustration 1) near the fixture, or remotely, one half of the distance the AC ballast manufacturer recommends remote mounting the AC ballast, or up to 50 feet, whichever is less. If no AC ballast is used, the CF750-4PT may be mounted up to 50 feet from the fixture.
2. Mount the test/monitor plate in the ceiling, next to the fixture, or remotely up to 50 feet from the fixture.

NOTE: Switch box is not supplied

Caution: Test switch must be installed in line with the unswitched AC source. ON switched fixtures, an additional unswitched hot wire, from the same branch circuit, must be supplied to the CF750-4PT (see wiring diagrams).

3. Install the momentary test switch and charging indicator in the test/monitor plate.

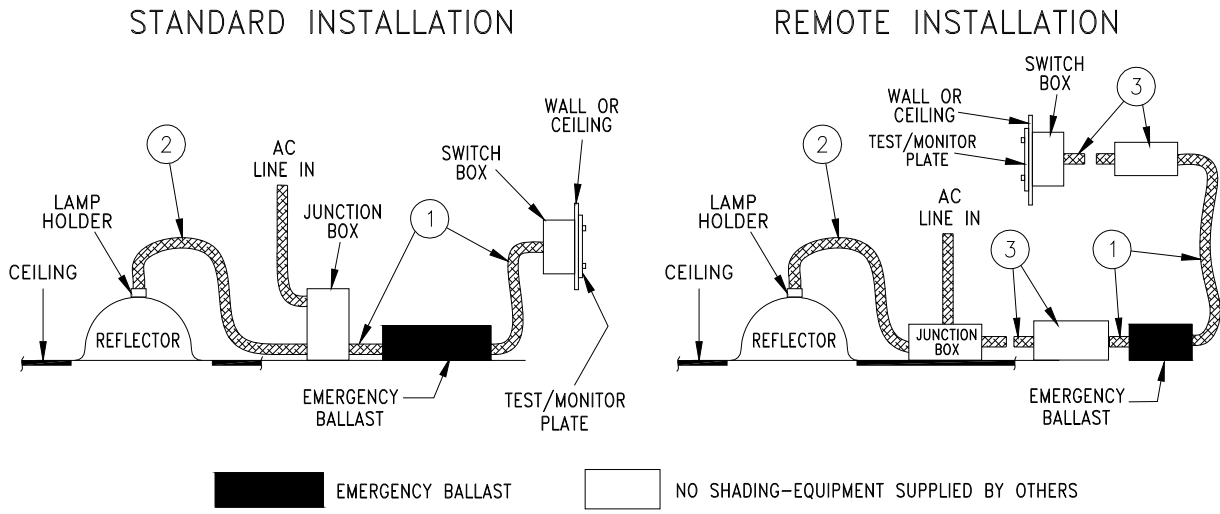
INSTALLATION CONT.

- (1) -Flexible conduit (supplied) to connect ballast wires.
- (2) -Existing conduit to run existing wires to lamp holder (AC ballast on junction box). If AC ballast is on reflector, run yellow/black, blue, and blue/white wires from emergency ballast through this conduit.
- (3) -Conduit and junction box (not supplied), necessary for remote installation.

4. Using the wiring diagrams provided, make all connections in accordance with the National Electric Code and any local requirements.
5. In a readily visible location, install the label "Caution – this unit has more than one power connection point. To reduce the risk of shock, disconnect both the branch circuit breakers or fuses and emergency power supplies before servicing."
6. Upon completion of installation, apply AC power to the CF750-4PT and connect the battery connectors.

OPERATION

1. After the AC power has been applied to the CF750-4PT, verify the charging indicator is illuminated. If not, refer to wiring diagrams and recheck wiring.
2. Allow the CF750-4PT battery to charge for one hour before performing any further testing. The CF750-4PT should be allowed to charge for a minimum of 72 hours before a full discharge test is performed.
3. After the initial one hour charge, a short term discharge test may be performed by pressing and holding the momentary test switch.
4. Verify the lamp(s) is lit, based on the chosen configuration, at a reduced illumination level, while the switch remains pressed.
5. If the fixture is used for emergency operation only, release the test switch and the lamp(s) will go out. If the fixture is used for normal and emergency operation, upon release of the test switch, the lamp(s) will remain out for approximately 4 seconds before returning to normal illumination levels.
6. If a full discharge test is being performed, remove AC power and verify the lamp(s) is illuminated, at a reduced level, for a minimum of 90 minutes, in accordance with UL924.

Note: If the unit fails to operate properly, please consult the manufacturer.

MAINTENANCE

Although no routine maintenance is required for the CF750-4PT, the following tests should be performed periodically to maintain compliance with national and local codes.

1. Monthly, visually check to see that the charging indicator is illuminated.
2. Test the CF750-4PT emergency ballast operation (see OPERATION section) at 30 day intervals for a minimum of 30 seconds.
3. Once a year, conduct a 90 minute discharge test (see OPERATION section).

WIRING DIAGRAMS

The following are typical wiring diagrams. Emergency and AC ballast must be fed from the same branch circuit. Please consult the factory for wiring diagrams not shown

ONE LAMP EMERGENCY OPERATION

A. ONE (1) LAMP RAPID START BALLAST

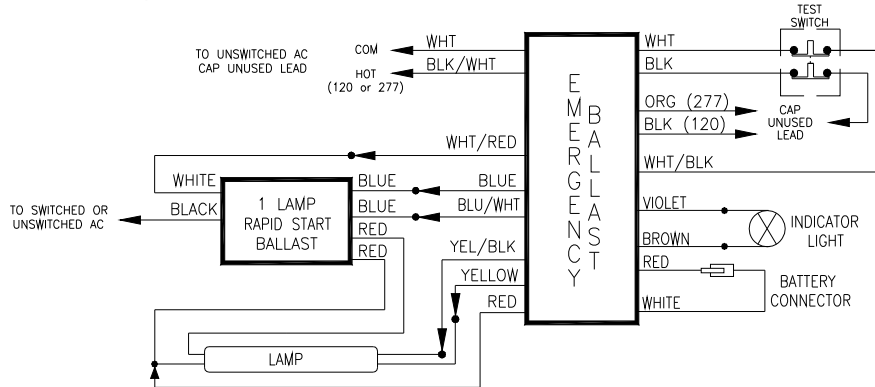

B. TWO (2) LAMP RAPID START BALLAST

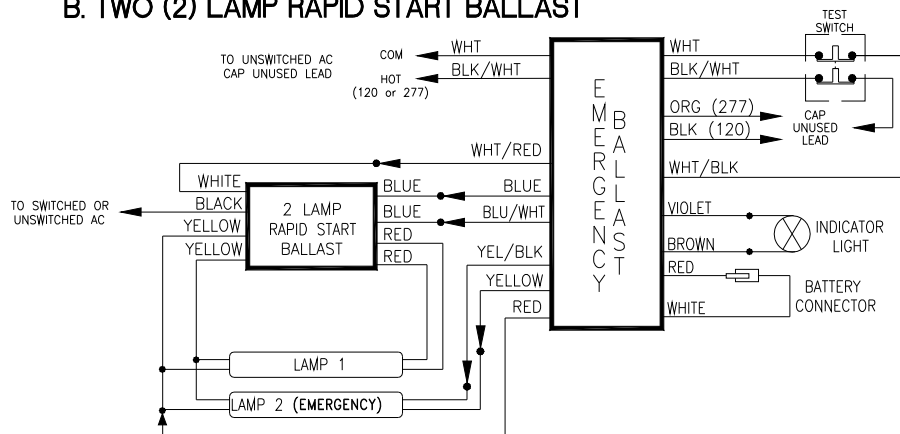

C. ONE (1) FOUR PIN COMPACT LAMP RAPID START BALLAST

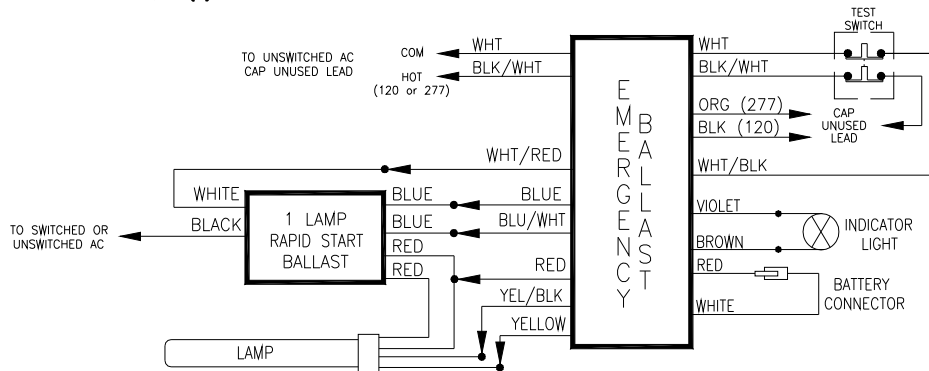

ONE LAMP EMERGENCY OPERATION CONT.

D. TWO (2) FOUR PIN COMPACT LAMP RAPID START BALLAST

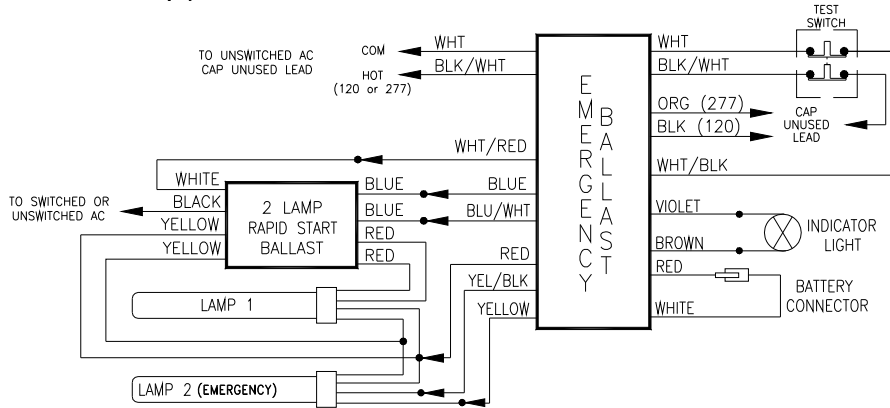

E. ONE (1) LAMP CIRCLINE RAPID START BALLAST

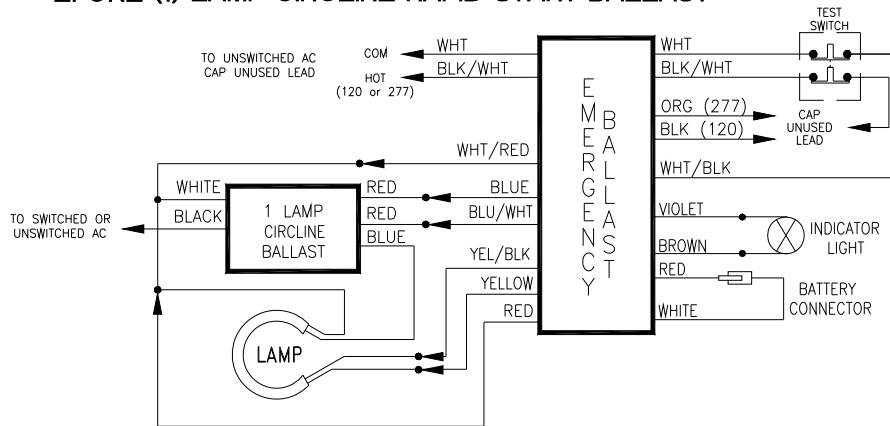

F. TWO (2) LAMP CIRCLINE RAPID START BALLAST

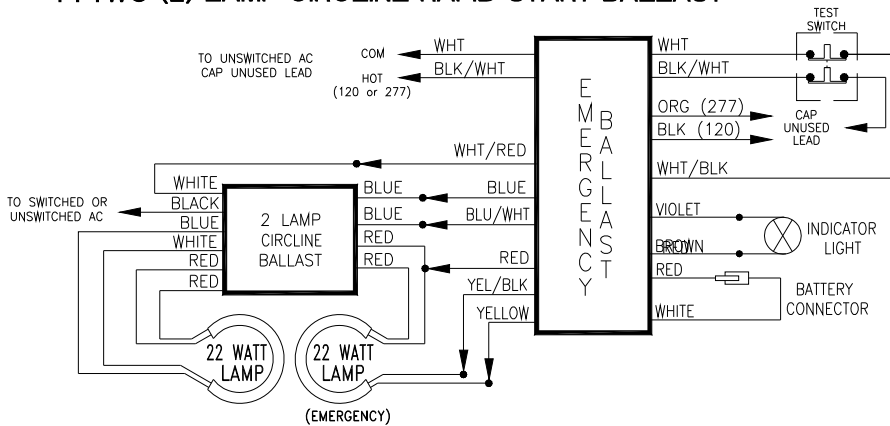

TWO LAMP EMERGENCY OPERATION

G. TWO (2) FOUR PIN COMPACT LAMP RAPID START BALLAST

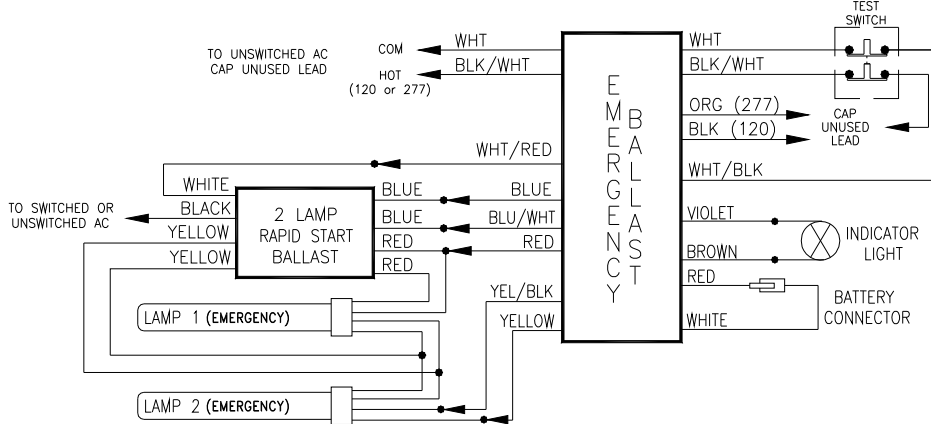

WIRING DIAGRAMS FOR EMERGENCY ONLY FIXTURES

H. ONE (1) LAMP WITHOUT AC BALLAST

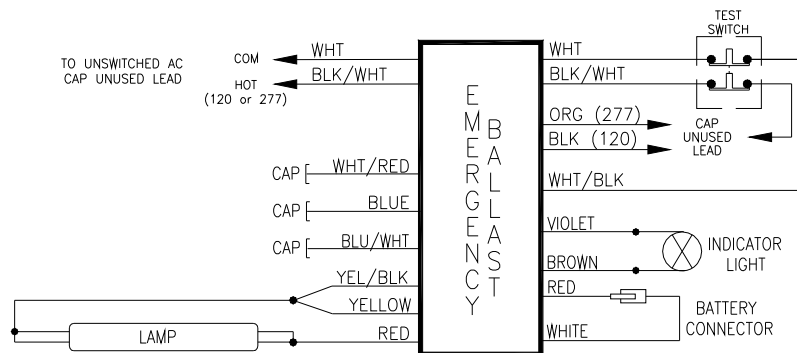

J. ONE (1) FOUR PIN COMPACT LAMP WITHOUT AC BALLAST

