

CHLORIDE SYSTEMS

TYPE: _____

CATALOG NO.: _____

GENERAL DESCRIPTION

The 4X Series is listed for wet or damp locations. The 4X Series is ideal for food processing and washdown areas. The 4X Series meets the Buy American requirements.

ILLUMINATION

Illumination is accomplished with lamp heads externally or internally mounted. The standard unit with external heads includes Chloride's "J" Series 6 or 12 volt lamp head in a variety of wattages. Units with internal heads may use the 5.4 watt, 7 watt, or 9 watt, 6 volt lamp heads. Optional lamp heads may be selected for external mounting only (refer to Options/Accessories Section)

DIMENSIONS

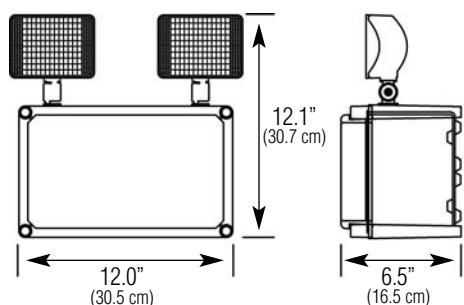

With Internal Heads (IH) Option

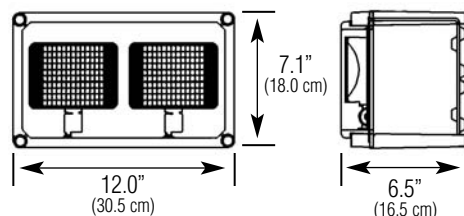

Dimensions are approximate and subject to change.

4X Series

6 and 12 Volt, 14 to 50 Watts Maintenance Free, Lead Calcium or Nickel Cadmium Battery

HOUSING

Constructed of impact-resistant, fiberglass-reinforced polyester. Housing color is gray.

Includes two black, rectangular thermoplastic 9 watt lamp heads externally mounted (See the Accessories Section for NEMA-rated lamp heads.)

Internally mounted white or black lamp heads available with "IH" option (up to 25 watt units only).

One-piece, molded gasket and unexposed metallic hardware prolong product life in highly corrosive areas.

ELECTRONICS

120/277 VAC dual voltage input with surge-protected, solid-state circuitry provides for a reliable charging system.

Charging system is complete with low voltage disconnect, AC lockout, brownout protection, AC indicator lamp and test switch.

BATTERY

Maintenance free, sealed lead calcium battery has an estimated service life of 10 years, and an operating temperature range of 65°F (19°C) to 85°F (30°C)

Maintenance free, nickel cadmium battery has an estimated service life of 12 years, and an operating temperature range of 20°F (-7°C) to 95°F (35°C)

Batteries supply 90 minutes of emergency power

ELECTRICAL SPECIFICATIONS

Input power requirements

120 VAC - 0.15 amps, 18 watts

277 VAC - 0.07 amps, 18 watts



SHOWN: 4X6L18

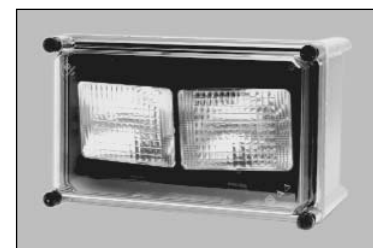

SHOWN: 4X6L18-IH2J66B

CODE COMPLIANCE

UL 924 listed

UL wet and damp location listings optional
50°F (10°C) to 104°F (40°C)

NFPA 101, NEC, BOCA, OSHA and IBC
illumination standards
NSF standard 2 "Splash Zone"

WARRANTY

Three year full electronics warranty

One year full plus four year prorated lead
calcium battery warranty

Five year full plus five year prorated nickel
cadmium battery warranty

ORDERING INFORMATION (EXAMPLE: 4X6L18IH2J66B)

4X					
SERIES	DC VOLTAGE	BATTERY	DC WATTAGE	FACTORY INSTALLED OPTIONS ¹	
4X = 4X Series	6 = 6 Volt 12 = 12 Volt	L = Lead Calcium N = Nickel Cadmium	Lead Calcium 6 Volt 18 = 18 Watts 25 = 25 Watts 36 = 36 Watts 50 = 50 Watts	Nickel Cadmium 6 Volt 14 = 14 Watts ³ 18 = 18 Watts 25 = 25 Watts 50 = 50 Watts	EX = Special Input Transformer ¹ (Specify voltage & frequency) IH = Internally Mounted Lamp Heads (up to 25 watt units only) TD1 = 120 VAC Time Delay ² TD2 = 277 VAC Time Delay ² TP = Tamperproof Lockup W = UL Wet Location Listing Z = UL Damp Location Listing
ACCESSORIES (order as a separate line item)					
EMF = External Mounting Feet NTPTOOL = Tamperproof Screwdriver PCS1 = Polycarbonate Vandal Shield WG5 = Wire Guard for Back Mount Units					
			12 Volt 36 = 36 Watts 50 = 50 Watts	12 Volt 50 = 50 Watts	

Specify for "IH" option only

2	
# OF HEADS	LAMP HEAD TYPE
2 = Two	<u>White</u> J66 = 6 Volt, 5.4 Watt J76 = 6 Volt, 7 Watt J96 = 6 Volt, 9 Watt
	<u>Black</u> J66B = 6 Volt, 5.4 Watt J76B = 6 Volt, 7 Watt J96B = 6 Volt, 9 Watt

NOTES: 1) Some option combinations may impact UL listing. Consult factory for specifics. 2) 15 minute delay. 3) Standard lamp head 7 watt, 6 VDC

Specification Data for 4X Series Emergency Lighting Units

HOUSING

Constructed of impact resistant, fiberglass reinforced polyester. Housing color is gray.

Includes one-piece, molded formed-in-place gasket and unexposed metallic hardware.

Includes two black, rectangular thermoplastic 9 watt externally mounted lamp heads. Internally mounted white or black lamp heads optional on units up to 25 watts.

LAMP HEAD PHOTOMETRICS

(For J96B, standard head for 6 volt versions. 4X6N14 uses J76B)

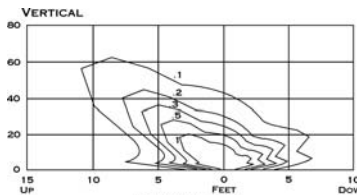
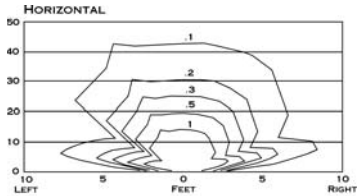

(For J912B, suggested head for 12 volt units)

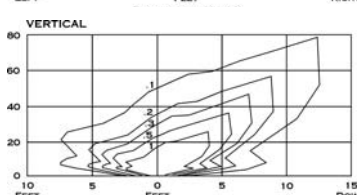
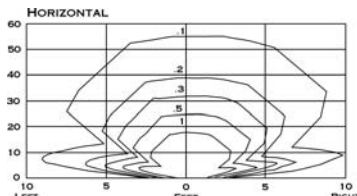

ELECTRONICS

120/277 VAC dual voltage input with surge-protected, solid-state charging circuitry provides for a reliable charging system. The charging system is furnished with low voltage disconnect, AC lockout, brownout protection, AC indicator lamp and test switch.

The low voltage disconnect (LVD) feature will disconnect the battery prior to an unacceptable deep discharge, but not before the required 90 minute emergency operation.

The AC lockout feature prevents battery drain prior to the initial energizing of utility power, and allows the installer to complete all wiring and electrical connections without energizing the emergency circuit.

The brownout protection circuitry will automatically switch the unit into the emergency mode if the utility voltage sags below 20% of nominal.

Battery charging circuitry is entirely solid-state, and utilizes a constant current charger for nickel cadmium battery units. A fully automatic, voltage regulated charger is used for lead calcium battery units. Battery recharge time after full discharge is less than the required UL 924 standard.

Line sensitive electronics cause an instantaneous transfer to battery power if utility power is lost, or a brownout condition is detected. When line voltage is present and stabilized, the transfer circuitry switches back to normal operation and begins recharging the battery. The transfer circuitry can be tested via a momentary test switch located on the housing.

UNIT ACCESSORIES

(Ordered Separately)

- EMF = External Mounting Feet
- NPTTOOL = Tamperproof Screwdriver
- PCS1 = Polycarbonate Vandal Shield
- WG5 = Wire Guard for Back Mount Units

BATTERY

Maintenance free, sealed nickel cadmium or lead calcium batteries are available.

Standard sustained emergency operation is for 90 minutes with the illumination source providing full light output.

The suggested operating temperature range for nickel cadmium batteries is 20°F (-7°C) to 95°F (35°C), and the battery has an expected service life of 10 years.

The suggested operating temperature range for sealed lead calcium batteries is 65°F (19°C) to 85°F (30°C), and the battery has an expected service life of 5 years.

ELECTRICAL SPECIFICATIONS

Input power requirements

- 120 VAC - 0.15 amps, 18 watts
- 277 VAC - 0.07 amps, 18 watts

CODE COMPLIANCE

The 4X Series meets or exceeds all performance standards as required by UL 924, NFPA 101, NEC, BOCA, OSHA and IBC. UL damp and UL wet location listings are optional.

OPERATION

DC Voltage	Unit	Watts to 87½ of Rated Voltage*			
		1½ hrs.	2 hrs.	4 hrs.	8 hrs.
6	4X6L18	18	14	7	—
	4X6L25	25	19	9.5	—
	4X6L36	36	27	14	7
	4X6L50	50	37.5	19	10
	4X6N14	14	10.5	5.5	—
	4X6N18	18	14	7	—
	4X6N25	25	19	9.5	—
12	4X12L36	36	27	14	7
	4X12L50	50	37.5	19	10
	4X12N50	50	37.5	19	10

* Per NEC Specifications

SUGGESTED SPECIFICATION

Furnish and install Chloride's emergency lighting unit model _____. The unit shall be constructed to meet Underwriter's Laboratories, Inc. Standard #924 and the National Electrical Code (NEC).

INSTALLATION AND OPERATION - Unit shall be easily field connected to a 120 or 277 VAC, 60 hertz, unswitched power source. Installation must comply with the NEC as well as other applicable codes. Upon utility power failure or brownout, the unit shall automatically transfer to battery power and maintain the required illumination level for a minimum period of 90 minutes. Upon restoration of utility power, the charger shall restore the battery to full charge within UL 924 requirements following a rated discharge of not more than 90 minutes.

CHARGER - Product shall utilize either a constant current (nickel cadmium) or fully automatic, voltage regulated (lead calcium) charging system. The charging system shall maintain the battery at full capacity without the need for periodic exercising or equalization. The following features shall be standard: low voltage disconnect (LVD), brownout protection and AC lockout.

BATTERY - The battery shall be either a maintenance free, sealed nickel cadmium or lead calcium battery. The nickel cadmium battery shall utilize sintered plate construction and polypropylene separators for trouble-free operation in ambient temperatures up to 95°F (35°C). The lead calcium battery shall provide trouble-free operation in temperatures up to 85°F (30°C). Nickel cadmium batteries shall be supplied with a five year full warranty, and lead calcium batteries shall be supplied with a one year full warranty.

HOUSING - The unit housing shall be constructed of impact-resistant, fiberglass-reinforced polyester. The housing color shall be gray.



272 West Stag Park Service Road • Burgaw NC 28425
 Telephone: (910) 259 1000 • Facsimile: (800) 258 8803
 www.chloridesys.com

C1061R18
 9/11 IH