

GENERAL DESCRIPTION

The C3000T5 fluorescent emergency ballast converts switched and unswitched fluorescent lighting into code required emergency lighting. The C3000T5 may be installed in or near the fixture to provide unobtrusive life safety protection.

ILLUMINATION

The C3000T5 provides 90 minutes of emergency illumination by utilizing existing fluorescent lighting and produces a maximum of 2,700 lumens initial emergency light output. The C3000T5 can be used with most 2'-4' 28 and 54 watt T5 HO lamps. The C3000T5 is also compatible with most 1, 2, 3 and 4-lamp electronic, standard, energy saving and dimming AC ballasts, including those with end of lamp life detection. See lamp operation for specific lamp types.

DIMENSIONS

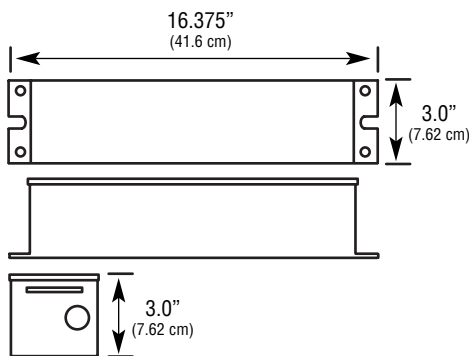

Dimensions are approximate and subject to change.

C3000T5

Fluorescent Emergency Ballast For Operating One T5/T5HO Lamp 2700 Lumen Maximum Output



HOUSING

Housing is constructed of 24 gauge steel with a high temperature white powder coat paint finish.

ELECTRONICS

120/277 VAC dual voltage input with surge protection, solid-state charging circuitry provides for a reliable charging system.

Charging system is complete with AC indicator lamp and test switch.

Fully compatible with AC ballast equipped with end of lamp life circuitry.

BATTERY

Maintenance free, sealed nickel cadmium battery

Supplies 90 minutes of emergency power

Estimated service life of 10 years

Operating temperature range of 32°F (0°C) to 131°F (55°C)

LAMP OPERATION¹

Operates the following lamp types²:

2'-4' 28 watt T5

2'-4' 54 watt T5 HO



SHOWN: C3000T5

CODE COMPLIANCE

UL 924 listed

Optional Damp Location listing for use in 0°C to 55°C NFPA 70 and NFPA 101, NEC, BOCA, OSHA and IBC illumination standards

ELECTRICAL SPECIFICATIONS

Input power requirements

120/277 VAC, 60 Hz, 4.5 watts

WARRANTY

Five year full electronics warranty

Five year full battery warranty

NOTES:

1) Consult factory for compatibility and performance of product with lamp types not listed.

2) See Table 1 for specific lamp performance and operation

ORDERING INFORMATION (EXAMPLE: C3000T5DL)

C3000T5

FLUORESCENT EMERGENCY BALLAST

C3000T5 = 2,700 Max. Lumen Output
Fluorescent Emergency
Ballast for One Operation



OPTIONS

DL = Damp Location Listing

ACCESSORIES

(order as a separate line item)

RTS2 = Remote Test Switch & Pilot Light Kit
(includes plate)

Specification Data for C3000T5 Fluorescent Emergency Ballast

HOUSING

Housing is constructed of 24 gauge metal with a high temperature powder coat paint finish.

ELECTRONICS

Dual voltage 120/277 VAC input is standard.

An indicator light and test switch are available to signify that AC utility is present, and periodically transfer to emergency operation.

Battery charging circuitry is entirely solid-state, and of a constant current design. Battery recharge time after a complete discharge is 24 hours.

Solid-state circuitry causes an instantaneous transfer to battery power if either the loss of AC utility, or a brownout condition is detected. When line voltage is present and stabilized, the transfer circuitry switches back to normal operation and begins recharging the battery. The transfer circuitry can be tested via a momentary test switch installed on the luminaire, or in a remote location.

A time delay circuit has been incorporated to provide a slight delay when switching back to AC operations. This prevents the AC ballast from shutting down due to a false end of lamp life detection.

BATTERY

Sealed, maintenance free nickel cadmium battery is equipped with a quick connect plug assembly for easy installation.

Standard sustained emergency operation is no less than 90 minutes with the illumination source providing full light output.

The suggested operating temperature range for nickel cadmium batteries is of 32°F (0°C) to 131°F (55°C) and should provide a service life of 10 years.

ELECTRICAL SPECIFICATIONS

Input power requirements
120/277 VAC, 60 Hz, 4.5 watts

CODE COMPLIANCE

The C3000T5 meets or exceeds all performance standards as required by UL 924, NEC, NFPA 70, NFPA 101, NEC, BOCA, OSHA and IBC.

LAMP OPERATION AND PERFORMANCE

Table 1

LAMP TYPE	WATTAGE	BASE TYPE	NON-EMERGENCY MAX. LUMEN OUTPUT	EMERGENCY OP. MAX. LUMEN OUTPUT	EMERGENCY LAMP OPERATION
F28W/T5	28	G5/Min Bi-Pin	2900	2450	One
F54/T5	54	G5/Min Bi-Pin	4600	2700	One

NOTES:

- 1) Maximum non-emergency lumen output can vary based on lamp manufacturer, ambient operating temperature, and ballast manufacturer.
- 2) Maximum emergency lumen output is based on total output of one lamp, and can vary based on lamp manufacturer and ambient operating temperature.
- 3) Consult factory for compatibility, operation and performance of lamp types not listed.

SUGGESTED SPECIFICATION

Furnish and install Chloride's fluorescent emergency ballast model C3000T5. The unit shall be constructed to meet Underwriter's Laboratories, Inc. Standard #924 and the National Electrical Code (NEC).

INSTALLATION AND OPERATION - Unit shall be easily field connected to a 120 or 277 VAC, 60 Hz, unswitched power source. Installation must comply with the NEC as well as other applicable codes. Upon utility power failure or brownout, the unit shall automatically transfer to battery power and maintain the required illumination for a minimum period of 90 minutes. Upon restoration of utility power, the charger shall restore the battery to full charge within UL 924 requirements following a rated discharge of not less than 90 minutes.

CHARGER - Unit shall utilize a solid-state, constant current charging system which will maintain the battery at full capacity without the need for periodic exercising or equalization.

TRANSFER - The transfer shall consist of a time delay circuit to provide a slight delay when switching back to AC operations. This prevents the AC ballast from shutting down due to a false end of lamp life detection.

BATTERY - The battery shall be a maintenance free, nickel cadmium battery. The nickel cadmium battery shall provide trouble-free operation in ambient temperatures up to 131°F (55°C). Nickel cadmium batteries shall be supplied with a five year full warranty.

ENCLOSURE - The housing shall be constructed of 24 gauge steel with a high temperature powder coat paint finish.



CHLORIDE
SYSTEMS

272 West Stag Park Service Road • Burgaw NC 28425
Telephone: (910) 259 1000 • Facsimile: (800) 258 8803
www.chloridesys.com

C1250
5/11 IH