

GENERAL DESCRIPTION

The CF1000-4PST converts switched and unswitched fluorescent lighting into code required emergency lighting. The CF1000-4PST may be installed in or near the fixture to provide unobtrusive life safety protection. The CF1000-4PST meets the Buy American requirements.

ILLUMINATION

The CF1000-4PST provides 90 minutes of emergency illumination by utilizing existing fluorescent lighting. The CF1000-4PST is compatible with standard energy-saving or electronic ballasts, and provides a 1000 lumen maximum output. See lamp operation for specific lamp types.

APPLICATION

The CF1000-4PST is suitable for commercial locations where emergency lighting protection is required using existing fluorescent lighting.

DIMENSIONS

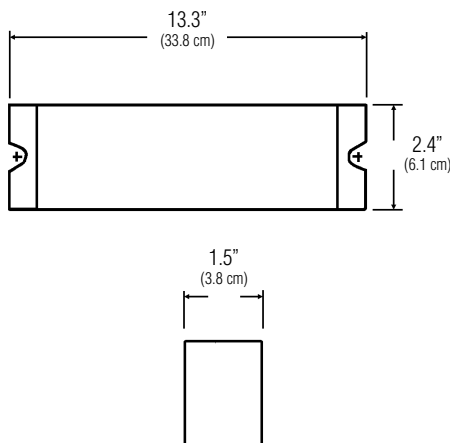

Dimensions are approximate and subject to change.

CF1000-4PST

Self-Diagnostic Fluorescent Emergency Ballast
1000 Lumen Maximum Output for 4-Pin Fluorescent Lamps
(without integral starter)



SHOWN: CF1000-4PST

HOUSING

Housing constructed of 20 gauge steel with a high temperature powder coat paint finish.

Housing allows for housing frame mounting on most recessed luminaires.

ELECTRONICS

120/277 VAC dual voltage input capability

Constant current charger restores battery to full charge within UL924 specifications

Compatible with most standard energy-saving magnetic or electronic lamp ballasts.

Charging system complete with AC indicator lamp, test switch, and mounting plate hardware.

BATTERY

Maintenance free, sealed nickel cadmium battery

Supplies 90 minutes of emergency power

Estimated service life of 10 years

Operating temperature range of 32°F (0°C) to 131°F (55°C)

LAMP OPERATION¹

Operates the following lamp types:²

T4 Compact Fluorescent (4-pin base)

13W - 50W twin, quad, and triple twin-tube

NOTES:

- 1) Consult factory for compatibility, operation and performance of product with lamp types not listed.
- 2) See table 1 on back for specific lamp performance and operation.

SELF-DIAGNOSTICS

Diagnostic circuit constantly monitors battery voltage and charging current, and will communicate a fault by flashing the status indicator lamp.

An automatic discharge test is also performed for 30 seconds every 30 days, and for 90 minutes every 12 months.

Automatic test satisfies the functional period test required by NFPA 101.

CODE COMPLIANCE

UL 924 listed

NFPA 70 and NFPA 101, NEC, BOCA, OSHA and IBC illumination standards

ELECTRICAL SPECIFICATIONS

Input power requirements

3.5 watts max.

WARRANTY

Two year full electronics warranty

Two year full battery warranty

ORDERING INFORMATION (EXAMPLE: CF1000-4PST)

CF1000-4PST

FLUORESCENT EMERGENCY BALLAST

CF1000-4PST = 1000 Lumen Max. Output Fluorescent Emergency Ballast for One or Two Lamp Operation

OPTIONS

EX = Special Input Transformer (Specify voltage and frequency)

ACCESSORIES
(order as a separate line item)

CCAPS = Wire Cover Kit for External Mounting

RTS = Remote Test Plate

RTS2 = Remote Test Switch & Pilot Light Kit (includes plate)

Specification Data for CF1000-4PST Fluorescent Emergency Ballast

HOUSING

Housing constructed of 20 gauge steel with a high temperature powder coat paint finish.

Housing is very compact, thus allowing for housing frame mounting on most recessed luminaires.

ELECTRONICS

Dual voltage 120/277 VAC input is standard.

An indicator light and test switch are available to signify that AC utility is present, and periodically transfer to emergency operation.

Battery charging circuitry is entirely solid-state, and of a constant voltage design. Battery recharge time after a complete discharge is less than the required UL 924 standard.

Solid-state circuitry causes an instantaneous transfer to battery power if either the loss of AC utility, or a brownout condition is detected. When line voltage is present and stabilized, the transfer circuitry switches back to normal operation and begins recharging the battery. The transfer circuitry can be tested via a momentary test switch installed on the luminaire, or in a remote location.

BATTERY

Sealed, maintenance free nickel cadmium battery is equipped with a quick connect plug assembly for easy installation.

Standard sustained emergency operation is for 90 minutes with the illumination source providing full light output.

The suggested operating temperature range for nickel cadmium batteries is of 32°F (0°C) to 131°F (55°C) and should provide a service life of 10 years.

ELECTRICAL SPECIFICATIONS

Input power requirements

3.5 watts max.

CODE COMPLIANCE

The CF1000-4PST meets or exceeds all performance standards as required by UL 924, NFPA 70, NFPA 101, NEC, BOCA, OSHA and IBC.

LAMP OPERATION AND PERFORMANCE

Table 1

LAMP TYPE	WATTAGE	BASE TYPE	NON-EMERGENCY MAX. LUMEN OUTPUT	EMERGENCY OP. MAX. LUMEN OUTPUT	EMERGENCY LAMP OPERATION
F13DBX/4P	13	G24Q-1	900	400	Two
F18DBX/4P	18	G24Q-2	1150	500	Two
F26DBX/4P	26	G24Q-3	1710	700	Two
F13TBX/4P	13	GX24Q-1	900	400	Two
F18TBX/4P	18	GX24Q-2	1200	500	Two
F26TBX/4P	26	GX24Q-3	1800	725	Two
F32TBX/4P	32	GX24Q-3	2200	750	One
F18BX	18	2G11	1250	450	Two
F27/24BX/RS	27	2G11	1800	600	One
F39/36BX/RS	39	2G11	2850	750	One
F40/30BX/RS	40	2G11	3150	750	One
F50BX/RS	50	2G11	4000	900	One
PL-T 42W/4P	42	GX24Q-4	3200	1000	One

NOTES:

- 1) Maximum non-emergency lumen output can vary based on lamp manufacturer, ambient operating temperature, and ballast manufacturer.
- 2) Maximum emergency lumen output is based on total output of one or two lamps, and can vary based on lamp manufacturer and ambient operating temperature.
- 3) Maximum emergency lumen output is supported for a full 90 minutes of operation.
- 4) Consult factory for compatibility, operation and performance of lamp types not listed.

SUGGESTED SPECIFICATION

Furnish and install Chloride's fluorescent emergency ballast model CF1000-4PST. The unit shall be constructed to meet Underwriter's Laboratories, Inc. Standard #924 and the National Electrical Code (NEC).

INSTALLATION AND OPERATION - Unit shall be easily field connected to a 120 or 277 VAC, 60 hertz, unswitched power source. Installation must comply with the NEC as well as other applicable codes. Upon utility power failure or brownout, the unit shall automatically transfer to battery power and maintain the required illumination for a minimum period of 90 minutes. Upon restoration of utility power, the charger shall restore the battery to full charge within UL 924 requirements following a rated discharge of not more than 90 minutes.

CHARGER - Unit shall utilize a solid-state, constant current charging system which will maintain the battery at full capacity without the need for periodic exercising or equalization.

BATTERY - The battery shall be a maintenance free, nickel cadmium battery. The nickel cadmium battery shall utilize sintered plate construction and polypropylene separators for trouble-free operation in ambient temperatures up to 131°F (35°C). Nickel cadmium batteries shall be supplied with a two year full warranty.

ENCLOSURE - The housing shall be constructed of 20 gauge steel with a high temperature powder coat paint finish. The slim housing shall allow for housing frame mounting on most recessed luminaires.



CHLORIDE
SYSTEMS

272 West Stag Park Service Road • Burgaw NC 28425
Telephone: (910) 259 1000 • Facsimile: (800) 258 8803
www.chloridesys.com

C1211R14
6/11 IH