

## GENERAL DESCRIPTION

The SPU Series is a self-contained emergency lighting unit that blends well with most contemporary interiors. The SPU Series is capable of surface, semi-recessed or fully recessed mounting. The SPU Series meets the Buy American requirements.

## ILLUMINATION

Illumination is provided by halogen lamps. Plus, the SPU Series features a highly reflective polished lens for increased illumination. The SPUL and SPU10 are furnished with a 12 watt halogen lamp. The SPU30M is furnished with a 7 watt halogen lamp.

## DIMENSIONS

### Surface Mount

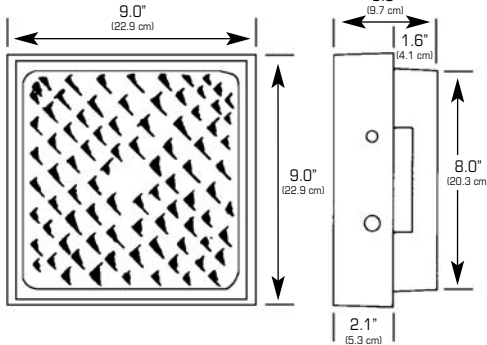

### Fully Recessed Mount

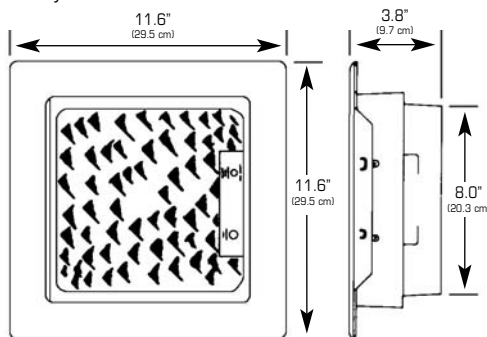

Dimensions are approximate and subject to change.

# SPU Series

## Self-Contained Emergency Lighting

### 6 and 12 Volt, 12 to 26 Watts

### Sealed Lead Calcium or Nickel Cadmium Battery

## HOUSING

Constructed of impact resistant, UL 94 V-0, 5 VA thermoplastic frame and backbox. The optional semi-recessed backbox is constructed of 22 gauge steel.

The frame is matte white and the backbox is black.

An acrylic lens is standard, and an optional shatter-resistant polycarbonate lens is available.

Unit may be surface, semi-recessed or fully recessed, and may be mounted directly to any standard four inch octagon or square junction box.

## ELECTRONICS

120/277 VAC dual voltage input with surge-protected, solid-state charging circuitry provides for a reliable charging system.

Charging system is complete with low voltage disconnect, AC lockout, brownout protection, AC indicator lamp and test switch.

## BATTERY

Maintenance free, sealed lead calcium battery has an estimated service life of 5 years, and an operating temperature range of 65°F (19°C) to 85°F (30°C)

Maintenance free, sealed nickel cadmium battery has an estimated service life of 10 years, and an operating temperature range of 20°F (-7°C) to 95°F (35°C)

Nickel cadmium batteries are recommended for semi- or fully recessed versions and high ambient temperature areas.

Batteries supply 90 minutes of emergency power

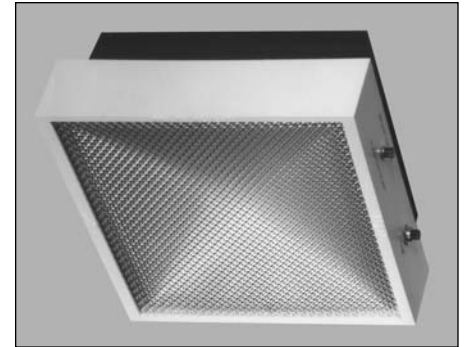

SHOWN: SPU10

## CODE COMPLIANCE

UL 924 listed

NFPA 101, NEC, BOCA, OSHA and IBC illumination standards

## ELECTRICAL SPECIFICATIONS

### Input power requirements

120 VAC - 0.096 amps, 10 watts

277 VAC - 0.04 amps, 10 watts

## WARRANTY

Three year full electronics warranty

One year full plus four year prorated lead calcium battery warranty

Five year full plus five year prorated nickel cadmium battery warranty

## ORDERING INFORMATION (EXAMPLE: SPU10FR)



**SERIES/BATTERY**



**MOUNTING CONFIGURATION**<sup>2</sup>

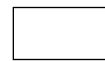

**OPTIONS**<sup>5</sup>

### Master Units

SPU10 = 6 Volt, 12 Watt, Nickel Cadmium Battery<sup>1</sup>

SPU30M = 6 Volt, 26 Watt, Nickel Cadmium Battery<sup>1</sup>

SPUL = 6 Volt, 12 Watt, Lead Calcium Battery

blank = Surface Mount

(For semi-recessed, order RMP1 accessory)

FR = Fully Recessed

V = Voltmeter

PC = Polycarbonate Lens

2L = Two 7w Lamps (SPU30M only)

### ACCESSORIES

(order as a separate line item)

RMP1 = Semi-recessed Kit

WG3 = Wire Guard

WG4 = Wire Guard for fully recessed unit

### Remote Units<sup>3</sup>

DLF6S = 6 Volt, 7 watt, surface mount

DLF12S = 12 Volt, 12 watt, surface mount<sup>4</sup>

DLF6FR = 6 volt, 7 watt, fully recessed

DLF12FR = 12 volt, 12 watt, fully recessed<sup>4</sup>

### NOTES:

1) Nickel cadmium units are recommended for recessed applications.

2) For semi-recessed applications, order the surface mount unit with the RMP1 accessory.

Fully recessed units can only be used on suspended ceilings.

3) DC wattage is determined by master unit.

4) 12 volt remote units can only be remoted with 12 volt single point units.

5) Some option combinations may impact UL listing. Consult factory for specifics.

# Specification Data for SPU Series Self-Contained Emergency Lighting Unit

## HOUSING

The frame and backbox are constructed of impact resistant, UL 94 V-0, 5 VA thermoplastic. The frame is a matte white thermoplastic, and the backbox is black thermoplastic.

The backbox for the semi-recessed version is constructed of 22 gauge steel.

An acrylic lens is standard, and an optional shatter-resistant polycarbonate lens is available.

The SPU series may be surface, semi-recessed or fully recessed, and may be mounted directly to any standard four inch octagon or square junction box.

## ELECTRONICS

120/277 VAC dual voltage input with surge-protected, solid-state charging circuitry provides for a reliable charging system. The charging system is furnished with low voltage disconnect, AC lockout, brownout protection, AC indicator lamp and test switch.

The low voltage disconnect (LVD) feature will disconnect the battery prior to an unacceptable deep discharge, but not before the required 90 minute emergency operation.

The AC lockout feature prevents battery drain prior to the initial energizing of utility power, and allows the installer to complete all wiring and electrical connections without energizing the emergency circuit.

The brownout protection circuitry will automatically switch the unit into the emergency mode if the utility voltage sags below 20% of nominal.

Battery charging circuitry is entirely solid-state, and utilizes a constant current charger for nickel cadmium battery units. A fully automatic, voltage regulated charger is used for lead calcium battery units. Battery recharge time after full discharge is less than the required UL 924 standard.

Line sensitive electronics cause an instantaneous transfer to battery power if utility power is lost, or a brownout condition is detected. When line voltage is present and stabilized, the transfer circuitry switches back to normal operation and begins recharging the battery. The transfer circuitry can be tested via a momentary test switch located on the housing.

## BATTERY

Maintenance free, sealed nickel cadmium or lead calcium batteries are available. All batteries are equipped with a quick connect plug assembly for easy installation.

Standard sustained emergency operation is for 90 minutes with the illumination source providing full light output.

The suggested operating temperature range for nickel cadmium batteries is 20°F (-7°C) to 95°F (35°C), and the battery has an expected service life of 10 years. The suggested operating range for sealed lead calcium batteries is 65°F (19°C) to 85°F (30°C), and the battery has an expected service life of 5 years.

## ELECTRICAL SPECIFICATIONS

### Input power requirements

120 VAC - 0.096 amps, 10 watts

277 VAC - 0.04 amps, 10 watts

## CODE COMPLIANCE

The SPU Series meets or exceeds all performance standards as required by UL 924, NFPA 101, NEC BOCA, OSHA and IBC.

## OPERATION

DC Voltage	Unit	Watts to 87½ of Rated Voltage*			
		1½ hrs.	2 hrs.	4 hrs.	8 hrs.
6	SPU10	12.0	9.0	—	—
	SPU30M	26	19.5	12.5	—
	SPUL	12.0	9.0	—	—

\* Per NEC Specifications

## SUGGESTED SPECIFICATION

Furnish and install Chloride's self-contained emergency lighting model \_\_\_\_\_. The unit shall be constructed to meet Underwriter's Laboratories, Inc. Standard #924 and the National Electrical Code (NEC).

**INSTALLATION AND OPERATION** - Unit shall be easily field connected to a 120 or 277 VAC, 60 hertz, unswitched power source. Installation must comply with the NEC as well as other applicable codes. Upon utility power failure or brownout, the unit shall automatically transfer to battery power and maintain the required illumination for a minimum period of 90 minutes. Upon restoration of utility power, the charger shall restore the battery to full charge within UL 924 requirements following a rated discharge of not more than 90 minutes.

**CHARGER** - Product shall utilize either a constant current (nickel cadmium) or fully automatic, voltage regulated (lead calcium) charging system. The charging system shall maintain the battery at full capacity without the need for periodic exercising or equalization. The following features shall be standard: low voltage disconnect (LVD), brownout protection and AC lockout.

**BATTERY** - The battery shall be either a maintenance free, sealed nickel cadmium or lead calcium battery. The nickel cadmium battery shall utilize sintered plate construction and polypropylene separators for trouble-free operation in ambient temperatures up to 95°F (35°C). The lead calcium battery shall provide trouble-free operation in temperatures up to 85°F (30°C). Nickel cadmium batteries shall be supplied with a five year full warranty, and sealed lead calcium batteries shall be supplied with a one year full warranty.

**ILLUMINATION** - The unit shall incorporate one 12 watt halogen lamp (SPUL, SPU10), or one 7 watt halogen lamps (SPU30M). A highly reflective polished lens shall be included for increased illumination.

**HOUSING** - The frame and backbox shall be constructed of impact resistant, UL 94 V-0, 5 VA thermoplastic. The frame shall be matte white, and the backbox shall be black. The semi-recessed version shall have a 22 gauge steel backbox.



**CHLORIDE**  
SYSTEMS

272 West Stag Park Service Road • Burgaw NC 28425  
Telephone: (910) 259 1000 • Facsimile: (800) 258 8803  
www.chloridesys.com

C1044R19  
11/11 IH