

CHLORIDE SYSTEMS

TYPE: _____

CATALOG NO.: _____

GENERAL DESCRIPTION

The Symmetry Vandal Series is designed to provide an attractive emergency lighting solution for damp/wet location, vandal prone or high abuse areas. The powerful MR16 halogen lamps are fully adjustable, and are secured by an attractive molded lampholder which conceals all lamp head wiring. The housing, backplate and electronics shell are injection molded from a premium impact resistant polycarbonate. Wet location units are fully gasketed to prevent water entry. The product is UL listed for damp locations as standard. With the optional battery heater, the wet location listed unit is rated for use in temperatures down to -4°F (-20°C). A tamperproofing screw kit is standard with all units. The SV16 meets the Buy American requirements.

ILLUMINATION

Illumination is provided by two high performance 5.5 watt, 6 VDC MR16-style halogen lamps. Lamps are held in an attractive molded swivel assembly, and are fully adjustable. When mounted on 18" centers (8' AFF) the SV16 will provide an average of one footcandle along a linear path of egress. IES photometric files are available.

INSTALLATION

Wet location units may be mounted to standard 3-1/2" and 4" octagonal junction boxes. Damp location units may be junction box or rigid conduit mounted.

DIMENSIONS

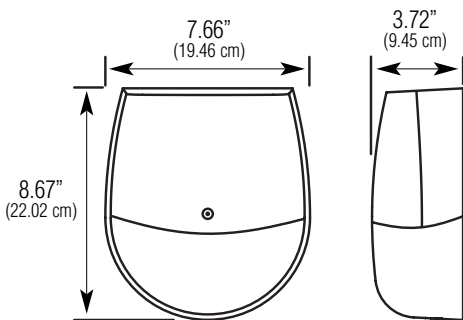

Dimensions are approximate and subject to change.

SV16

Damp/Wet Location Units

Polycarbonate Construction

6 Volt, 11 Watt Unit

Maintenance Free, Sealed Lead Calcium Battery



HOUSING

The high abuse housing, backplate and electronics shell are molded from high impact, GE Lexan® polycarbonate. All injection molded components meet the UL 94 V-0, 5 VA flame retardant standard for emergency lighting products.

White housing is standard, with an optional black or bronze housing available.

All units are supplied standard with a UL damp location listing and tamperproof screw kit. Optional wet location listed products include a fully gasketed cover. Standard non-tamperproof screws are also included with the product.

Installation is simplified by the use of a snap-together backplate and housing. When installed with the supplied tamperproof screw kit, removal from mounting surface, or removal of outer protective cover is not possible under normal service conditions without the use of a torx T-15 bit.

Utility supply is completed by use of a modular plug-in wiring harness. A convenient knockout is also made available in the top right section of product to accommodate 1/2" conduit (damp location listed units only).

ELECTRONICS

120/277 VAC dual voltage input with surge-protected, solid-state, fully automatic, voltage regulated charger.

Charging system is complete with low voltage disconnect, AC lockout, brownout protection and combination indicator lamp and illuminated test switch. All circuit board components are coated with a moisture resistant protector.

OPERATING TEMPERATURE RANGE

Damp location: 50°F (10°C) to 104°F (40°C)

Wet location: 41°F (5°C) to 104°F (40°C)

Wet location with heater: -4°F (-20°C) to 104°F (40°C)



SHOWN: SV16LW

BATTERY

Maintenance free, sealed lead calcium battery

Supplies 90 minutes of emergency power

Estimated service life of 5 years

CODE COMPLIANCE

UL 924 listed

UL damp location listed

UL wet location listing optional

NFPA 101, NEC, BOCA, OSHA and IBC illumination standards

Meets ADA specifications for wall mounted lighting fixtures

ELECTRICAL SPECIFICATIONS

Input power requirements

120 VAC - 0.05 amps

- 0.30 amps (with heater option)

277 VAC - 0.02 amps

- 0.13 amps (with heater option)

WARRANTY

Three year full electronics warranty

One year full plus four year prorated battery warranty

ORDERING INFORMATION (EXAMPLE: SV16LW)

SV16	L		
SERIES	BATTERY	HOUSING COLOR	LOCATION LISTING
SV16 = Symmetry Vandal Series, 11 Watt	L = Lead Calcium	W = White B = Black BZ = Bronze	Blank = Damp Location Listed WL = Wet Location Listed HR = Wet Location Listed with Battery Heater

ACCESSORIES
(order as a separate line item)
T15TPTOOL = Tamperproof Tool

Specification Data for SV16 Symmetry Vandal Series

ILLUMINATION

I.E.S. format photometric data files are available for use with most lighting layout application software.
Contact: Chloride Technical Service for specific layout assistance.

OPTICAL PERFORMANCE*

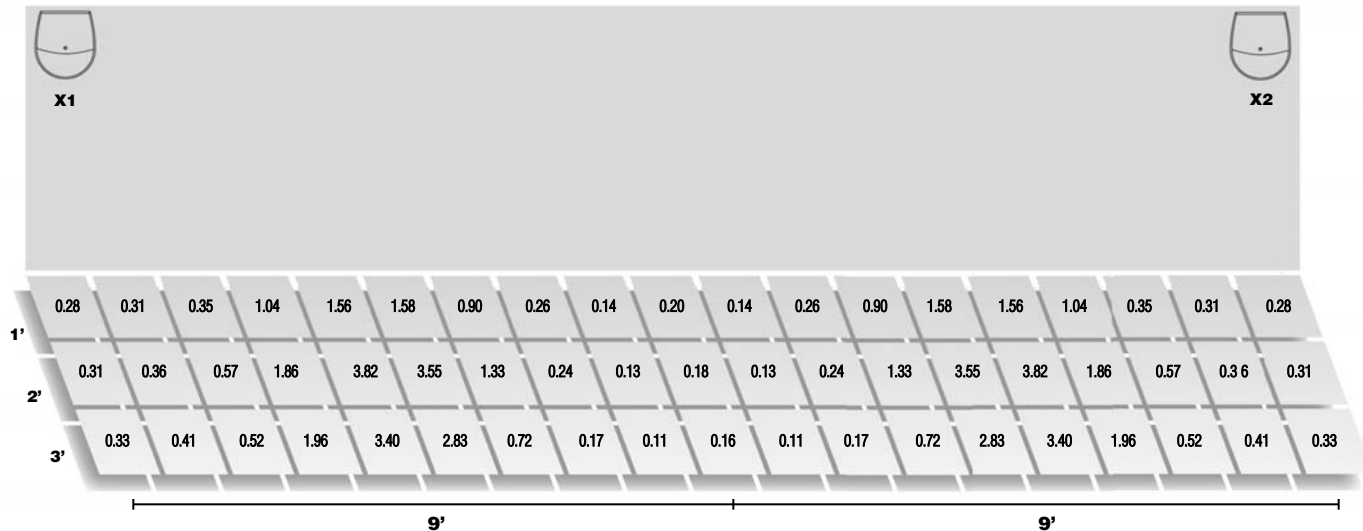

Chart represents (2) luminaires mounted on 18' centers, mounting height 8' AFF

X1 = Luminaire Location #1

X2 = Luminaire Location #2

Average initial footcandles at floor = 1.03
Maximum initial footcandles at floor = 3.82

Minimum initial footcandles at floor = 0.28
Maximum to minimum ratio = 13.7:1

* The optics layout is intended to be used as a reference only. Standard reflectance, 80/50/20 were used. Chloride Systems is not responsible for site specific conditions that may alter the results.

SUGGESTED SPECIFICATION

Furnish and install Chloride's vandal resistant emergency lighting model _____. The unit shall be constructed to meet Underwriter's Laboratories, Inc. Standard 924 and must be installed to conform to Article 700 of the National Electrical Code (NEC).

INSTALLATION AND OPERATION - Unit shall be easily field connected to a 120 or 277 VAC, 60 hertz, unswitched power source. Installation must comply with the NEC as well as other applicable codes. Upon utility power failure or brownout condition, the unit shall automatically provide emergency battery power and maintain the stated illumination level and output wattage for a minimum period of 90 minutes. Upon restoration of utility power, the charging circuitry shall restore the battery to full charge within UL 924 requirements following a rated discharge of not more than 90 minutes.

CHARGING CIRCUITRY - Unit shall utilize a solid-state, fully automatic, voltage regulated charging system which will maintain the battery at full capacity without the need for periodic exercising or equalization. The following features shall be standard: low voltage disconnect (LVD), brownout protection and AC lockout.

BATTERY - The battery shall be maintenance free, sealed lead calcium type. The battery shall provide trouble-free operation in temperatures up to 104°F (40°C) and is supplied with a one year full, four year pro-rata warranty.

ILLUMINATION - Illumination shall be provided by two internally mounted MR16 style 5.5 watt halogen lamps. When mounted on 18' centers (8' AFF) the unit shall provide an average of 1 footcandle between luminaires from base of wall to 3' from wall. Lamp assemblies must be capable of 180° horizontal rotation and 160° vertical rotation.

HOUSING - Outer cover, backplate and electronics shell shall be injection molded from GE Lexan® polycarbonate, listed to 94 V-0, 5 VA standards. Backplate shall be compatible for mechanical fastening to 3-1/2" or 4" octagonal or 4" square junction boxes and be supplied with a knockout pattern to facilitate mounting. Modular utility supply connectors shall eliminate hardware line voltage terminations inside the product housing, except when utility supply is provided via surface conduit (damp location listed units only). Regular and tamperproof screws shall be provided along with weather resistant gasketed construction. When installed using the supplied tamperproof screw kit, product shall not be capable of removal from wall, or subject to opening of electronics compartment with standard tools.

® Lexan is a registered trademark of General Electric Company



CHLORIDE
SYSTEMS

272 West Stag Park Service Road • Burgaw NC 28425
Telephone: (910) 259 1000 • Facsimile: (800) 258 8803
www.chloridesys.com

C1345R12
9/11 IH