

## GENERAL DESCRIPTION

Splendore is an industry first – a state of the art architectural emergency lighting product based on high-output white LEDs. Nickel metal hydride batteries and a diagnostic charger further enhance its reliability and performance. Developed to rigorous optical design criteria, Splendore offers unsurpassed lighting performance capable of lighting up to 50 linear feet to one footcandle average. It is available in a wide range of decorative finishes to blend with any setting. Die cast exits with complementary finishes are also available. Splendore meets the Buy American requirements.

## ILLUMINATION

Illumination is provided by two 5 watt, white LEDs and a specular Miro 4 (Alanod™) aluminum reflector. The lamp head assembly may be rotated in five-degree increments over a range of 60 degrees for ideal distribution along the egress path. Splendore will provide one foot-candle average illumination over a 50' long path of egress. IES photometric data files are available.

## INSTALLATION

Splendore is designed to be wall mounted to a 3-1/2" octagonal junction box. Installation is quick and easy using simple two-piece snap together construction. The backplate is provided with convenient keyhole slots for mounting and a tamperproofing option is available.

## DIMENSIONS

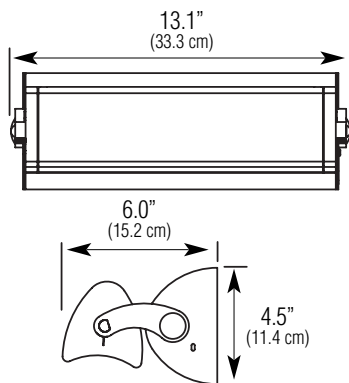

Dimensions are approximate and subject to change.

# Splendore

## Architectural Emergency Light

### 7.2 Volt, 10 Watt LED Lamps

### NiMH Battery, Diagnostic Charger

### 1 Footcandle Average at Up to 50 Feet



## HOUSING

Robust die cast and extruded aluminum housing. A full range of pleasing architecturally inspired finishes are available (see below). Wall mount to standard 3 1/2" octagonal junction box.

## ELECTRONICS

120/277 VAC dual voltage input with solid state charging circuitry provides for a reliable charging system.

Microprocessor-based, solid-state circuitry controls and monitors all charge functions.

Standard self-diagnostic electronics perform an automatic one minute test of emergency operation every 30 days and a similar 30 minute test every 180 days. This test verifies fixture activation, battery capacity and lamp operation.

User may initiate a 1 minute or 90 minute test manually using the test switch or available infrared remote.

Charging system is complete with low voltage disconnect, AC lockout, brownout protection, AC indicator lamp and test switch.

## ELECTRICAL SPECIFICATIONS

Achievable Emergency Illumination  
One footcandle average with adjacent fixtures mounted on 50' centers.

Operating Time  
120 minutes of emergency operation

Input power requirements  
120 VAC - 0.09 Amps  
277 VAC - 0.03 Amps

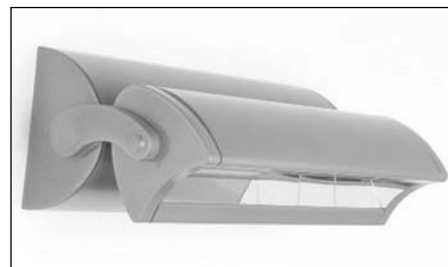

SHOWN: SN

## BATTERY

Maintenance-free sealed nickel metal hydride with 10-year life.

Supplies 120 minutes of emergency power.

## CODE COMPLIANCE

UL 924

UL damp location listing optional

NFPA 101, NEC, BOCA, OSHA and IBC illumination standards

Approved for use in the city of Chicago.

## WARRANTY

Three year full electronics warranty.

Five year full plus five year prorated NiMH battery warranty.

## OPERATING TEMPERATURE RANGE

Standard: 65°F (19°C) to 85°F (30°C).

Damp location: 50°F (10°C) to 104°F (40°C)

## ORDERING INFORMATION (EXAMPLE: SN)



### SERIES

S = Splendore



### HOUSING COLOR

W = White  
B = Black  
A = Aluminum  
G = Gunmetal  
BR = Ornamental Bronze  
AC = Aged Copper  
VG = Velvet Green  
N = Nickel

Consult factory for other colors.



### FACTORY INSTALLED OPTIONS

TP = Tamperproof  
DL = Damp Location

### ACCESSORIES (order as a separate line item)

CHLREMOTE = Infrared Remote Control

# Specification Data for Splendore 7.2 Volt, 10 Watt Architectural Emergency Light

## OPTICS\* WALL MOUNTED 7.5' AFF

Double Luminaire

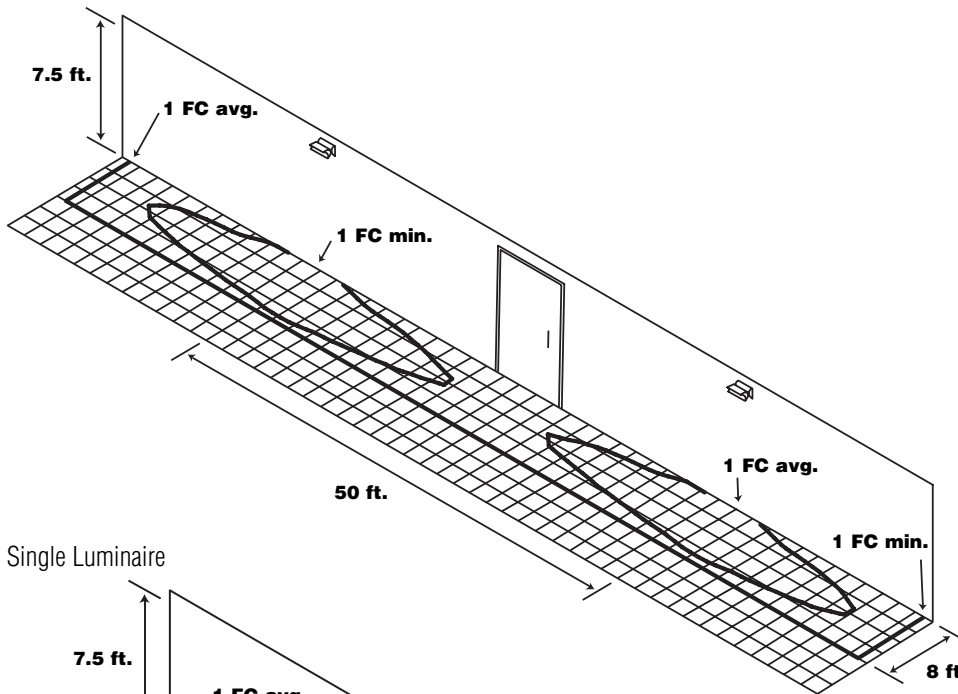

Average initial footcandles = 1.2  
Maximum initial footcandles = 3.9  
Minimum initial footcandles = 0.3  
Maximum to minimum ratio = 13.0

Single Luminaire

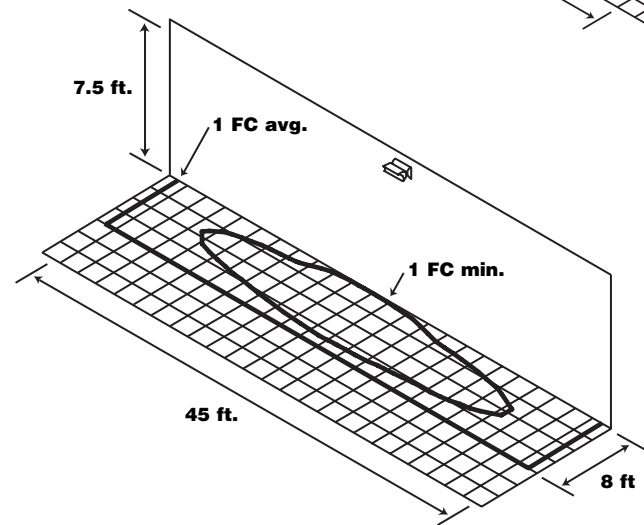

Average initial footcandles = 1.17  
Maximum initial footcandles = 3.9  
Minimum initial footcandles = 0.1  
Maximum to minimum ratio = 39.0

\*The optics layout is intended to be used as reference only. Standard reflectances used were 80/50/20. Chloride is not responsible for site specific conditions that may alter the results.

### SUGGESTED SPECIFICATION

Furnish and install Chloride's emergency lighting model Splendore. The unit shall be constructed to meet Underwriters Laboratories, Inc. Standard #924 and must be installed to conform to Article 700 of the National Electrical Code (NEC).

**INSTALLATION AND OPERATION** – Unit shall be easily field connected to a 120 or 277 VAC, 60 hertz, unswitched power source. Installation must comply with the NEC as well as other applicable codes. Upon utility power failure or brownout, the unit shall automatically provide emergency battery power and maintain the stated illumination level and output wattage for a minimum period of 120 minutes. Upon restoration of utility power, the charging circuitry shall restore the battery to full charge within UL 924 requirements following a rated discharge of not more than 120 minutes.

**CHARGING CIRCUITRY** – Unit shall utilize a fully automatic, microprocessor controlled charging system. The charging system shall maintain the battery at full capacity without the need for periodic exercising or equalization. The following features shall be standard: low voltage disconnect (LVD), brownout protection, AC lockout and self-test/self-diagnostics. Self-test/self-diagnostics shall monitor and indicate a fault occurring in either the charger, battery, lamp circuit or input supply.

**BATTERY** – The battery shall be maintenance-free nickel metal hydride. The NiMH battery shall provide trouble-free operation in temperatures ranging from 65°F (19°C) to 85°F (30°C) in standard indoor applications and 50°F (10°C) to 104°F (40°C) in damp location models. The battery shall be supplied with a five-year full warranty.

**ILLUMINATION** – Illumination shall be provided by an engineered Miro 4 reflector and two five-watt white LED lamps. Adjacent fixtures mounted 50 feet apart shall provide one foot-candle average when mounted at a 7.5' mounting height.

**HOUSING** – Housing construction shall be of cast and extruded aluminum. The unit shall be available in multiple colors and finishes. The unit shall be wall mounted to a standard 3½" octagonal junction box.



**CHLORIDE**  
SYSTEMS

272 West Stag Park Service Road • Burgaw NC 28425  
Telephone: (910) 259 1000 • Facsimile: (800) 258 8803  
www.chloridesys.com



C1310R13  
9/11 IH