

## PathMaster

### LED Illuminated Bollard with Composite Construction



**DIMENSIONS (36.0" H X 5.0" W X 5.0" D)**

#### GENERAL DESCRIPTION

The PathMaster LED Bollard is designed to provide energy efficient illumination of walkways, decks, sidewalks, and landscape areas for normal and emergency power failure use. Non-weathering composite construction combined with versatile mounting configurations makes the PathMaster LED bollard a natural choice for coastal environments, parks, and residential applications. The PathMaster LED light engine can be applied from one to four sides as needed for proper illumination without wasted light spill, and provides warm 3500 Kelvin illumination covering a 64 sq/ft area to 1 foot-candle. The PathMaster LED Bollard meets the Buy American requirements.

#### APPLICATION

The PathMaster LED Bollard can be used for both general and/or emergency illumination and is designed to be installed via 1/4"-20"x8"x2" stainless steel anchors secured in concrete, or other solid surfaces. A 2" conduit entry area is available through the bottom of unit. The product is also available in a direct burial model which is supplied with a below grade conduit entry area. Product supplied with single and multiple LED luminaires includes a convenient wiring harness that is suitable for hardwiring to the utility input. Low voltage models should be hardwired to accept both "Normally On" and "Emergency" power from the PathMaster remote mounted power panel. To effectively control light spill and light trespass, the PathMaster LED Bollard can be specified to include from one to four LED light engines installed on any side of the product. Photometric templates are available to display performance of products including single and multiple luminaires.

#### CONSTRUCTION

The PathMaster LED Bollard is fabricated in a heat formed pultruding process that utilizes fiberglass reinforced polymers as the base process material. The anchor base model is 36"Hx5"Wx5"D and includes a specially designed heavy gauge galvanized base collar with provisions for a four bolt anchoring system. All exposed hardware is stainless steel, with the LED light engines embedded and sealed within the composite structure. The LED light engines are constructed of die cast aluminum with all diffusers fabricated from injection molded, UV stabilized, polycarbonate material. The bollard shaft is painted via an automated paint system, with LED light engines finished in a durable power coat paint process.

#### ILLUMINATION

The PathMaster LED Bollard can be specified to utilize from one to four white LED light engines. Each LED light engine is manufactured using three 3500 Kelvin white LED devices supported by a LED driver circuit designed specifically to support this LED light engine. Power consumption per LED light engine is 10 watts, and supports a continuous duty service life of 10 years or 40,000 hours to 75% illumination levels. Actual photometric performance charts are shown on page two of this data sheet.

#### CODE COMPLIANCE

ETL listed to UL standards 1598 and 1838

#### WARRANTY

Three year full warranty on electronics and composite bollard body.

### ORDERING INFORMATION (EXAMPLE: PBBZA490BK2)

PB					
<b>SERIES</b>	<b>BOLLARD FINISH</b>	<b>BASE TYPE</b>	<b># LUMINAIRES &amp; ORIENTATION</b>	<b>LUMINAIRE FINISH</b>	<b>INPUT VOLTAGE</b>
PB = PathMaster Bollard Series	BZ = Bronze BK = Black XX = Custom	A = Anchor Base D = Direct Burial L = Lag Bolt	190 = (1) @ 90 Degrees 290 = (2) @ 90 Degrees 390 = (3) @ 90 Degrees 490 = (4) @ 90 Degrees 2180 = (2) @ 180 Degrees	BK = Black BZ = Bronze WH = White XX = Custom	1 = 12 VAC/VDC 2 = 120 VAC

**ACCESSORIES (order as a separate line item)**  
 PMPS1 = PathMaster Low Voltage Power System for Normal and Emergency Power Support (compatible with 12 VAC/VDC models only)

# Specification Data for PathMaster LED Bollard

## PERFORMANCE

Single Light Engine

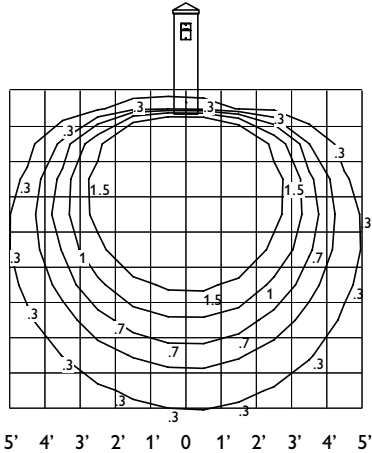

Dual (180°) Light Engines

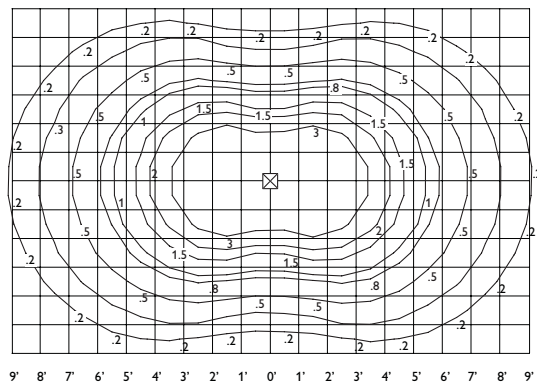

Quad (4 x 90°) Light Engines

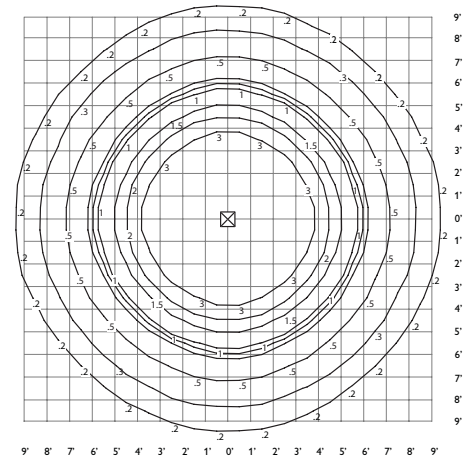

## INSTALLATION DETAIL

Base Details

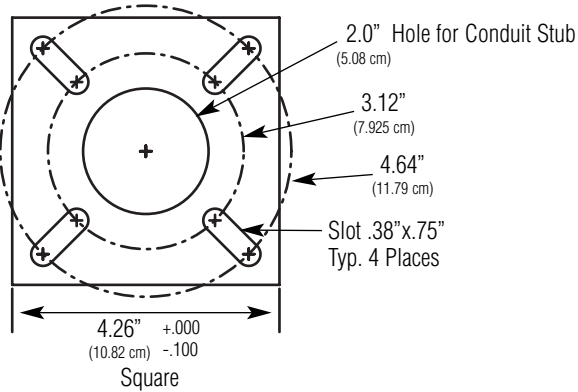

Overall Dimensions

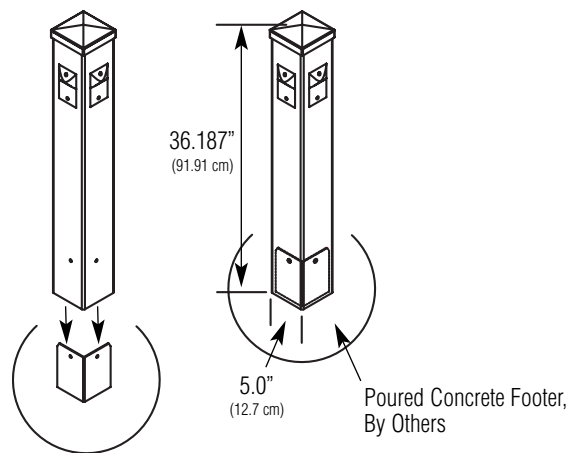

## SUGGESTED SPECIFICATION

Furnish and install Chloride's PathMaster model number \_\_\_\_\_. This product shall be constructed to meet Underwriter's Laboratories standard 1598 (120 VAC models) or standard 1838 (12 VAC models), and must be installed to conform with Article 700 of the National Electrical Code (NEC).

**INSTALLATION** - The PathMaster LED Bollard (anchor base models) shall include a 4.26" x 4.26" galvanized steel mounting base integral to the composite bollard housing, and secured to the foundation via four 1/4"-20"x8"x2" stainless steel anchor bolts set in concrete. Lag bolt anchored models shall include the same mounting base described above, however will utilize special galvanized expanding lag bolts suitable for use in concrete, masonry, or wood foundations. Embedded base models shall have provisions for below ground conduit entry, and must be buried to comply with standards as required in the National Electrical Code (NEC). All supply wiring shall be 18 AWG minimum and comply with the NEC and local electrical codes.

**ILLUMINATION** - The PathMaster LED Bollard will utilize one, two, three, or four 3500 Kelvin white LED light engine(s) flush mounted at 90 degrees to the bollard housing. Each LED light engine shall consume no more than 10 watts, with maximum utilization of four LED light engines used per bollard (40 watts). The LED light engines will be rated for a minimum of 40,000 hours continuous duty operation, or 10 years continuous operation to 75% light output. The LED devices incorporated in this product shall be capable of replacement service, and the manufacturer shall make available spare component part numbers. The PathMaster LED Bollard models utilizing four LED light engines mounted at 90 degrees shall produce an average of one footcandle at ground level over a 64 square foot area. IES photometric files as well as software point-by-point simulation layouts shall be made available by the manufacturer.

**CONSTRUCTION** - The PathMaster LED Bollard housing shall be fabricated by a specialized pulltruding process that utilizes heat saturated fiberglass reinforced polymers as the base process material. The anchor base, anchor bolts, and/or lag bolts provided with product shall be constructed from heavy gauge galvanized steel. All other exposed hardware shall be fabricated from stainless steel. The LED light engines shall be flush embedded and sealed within the composite structure. The LED light engines shall be constructed of die cast aluminum with all diffusers fabricated from injection molded, UV stabilized polycarbonate. The bollard housing shall be painted via an automated paint system, with LED light engines finished in a durable power coat paint process.



**CHLORIDE**  
SYSTEMS

272 West Stag Park Service Road • Burgaw NC 28425  
Telephone: (910) 259 1000 • Facsimile: (800) 258 8803  
www.chloridesys.com

C1603R6  
9/11 IH