

CHARACTERISTICS

Overall

87% throughput efficiency, 85% emergency efficiency

Operating temperature range 32°F (0°C) to 104°F (40°C)*

Fault current rating 42kAIC

Audible noise less than 50dB at 3 ft on "A" weighted scale

Automatic low battery voltage disconnect

Output

Sine wave output

Voltage regulation ±2%

Frequency regulation- Synchronized to utility
Free running 60Hz, ±0.5%

Output voltage distortion maximum 3%THD with linear load

Load power factor capability 0.7 lead to 0.7 lag

Overload capability 125% for 10 seconds

Input

Input power factor correcting to 0.99

Frequency range 60Hz, ±2.5Hz

Input harmonic current distortion < 5%THD

UL1449, ANSI/IEEE C62.41 surge suppression

*Optimum operating temperature of batteries is 77°F (25°C). Temperatures above 85°F (30°C) adversely impact battery life

Synthesis CHT Series

6,000VA Single Phase

Uninterruptible Power Supplies (UPS) for Emergency Lighting Applications

FEATURES

Double conversion- no interruption

Solid state Pulse Width Modulated inverter

Internal, make before break maintenance by-pass

Standard, UL 924 compliant, 90 minute battery back up

UL 924 auxiliary equipment 10 and 20 minute back up available

Microprocessor control and diagnostic system

LCD readout system status panel

Local 25 event logging/display

User programmable automatic testing

Load integrity testing

Fault annunciating audible alarm

Current limiting start sequence

Optional output circuit breakers (OCB) and circuit breakers with trip alarm (OCBA)

Optional normally off load (NOL) energizes only during power outage, normally off load with time delay (TDT) also available

Free standing NEMA1 enclosure

Lockable control access panel

Seismic anchoring compatible



Listed to UL 924



APPLICATIONS

The solid state Pulse Width Modulated (PWM) inverter offers enhanced load compatibility

It operates incandescent, magnetic and electronic ballast fluorescent, high power factor compact fluorescent and high intensity discharge (HID) luminaries

Provides conditioned, uninterruptible power for other types of critical loads. Consult factory for non-lighting load applications.

ORDERING INFORMATION

CHT			6.0							
SERIES	INPUT VOLTAGE	OUTPUT VOLTAGE	UNIT SIZE	BATTERY TIME	NOL	QTY CKT BREAKERS	BREAKERS On 2nd VOLTAGE	QTY NOL CKT BREAKERS	NOL VOLTAGE	QTY NOL 2nd VOLTAGE
CHT = Chloride Synthesis CHT UPS System for Emergency Lighting Applications	G = 120/240V J = 277V L = 120/208V	G = 120/240V J = 277V L = 120/208V Y = 120/277V	6.0 = 6.0 kVA	S = 90 min Y = 20 min	0 = None 1 = Yes T = NOL w/ TDT	00X = Hardwire 01X = 1 OCB 02X = 2 OCB 03X = 3 OCB 04X = 4 OCB : : 20X = 20 OCB ----- 01A = 1 OCBA 02A = 2 OCBA 03A = 3 OCBA : : 10A = 10 OCBA Maximum Pole Spaces 20	00 = 2nd Voltage Hardwire or no 2nd Voltage 01 02 03 : : 19	A = 1 B = 2 C = 3 D = 4 E = 5 F = 6 G = 7 H = 8 I = 9 J = 10 K = 11 L = 12 M = 13 N = 14 O = 15 P = 16 Q = 17 R = 18 S = 19 T = 20 Z = None	1 = First 2 = Second 3 = Both 0 = No NOL	A = 1 B = 2 C = 3 D = 4 E = 5 F = 6 G = 7 H = 8 I = 9 J = 10 K = 11 L = 12 M = 13 N = 14 O = 15 P = 16 Q = 17 R = 18 S = 19 Z = No NOL

DIMENSIONS/WEIGHTS

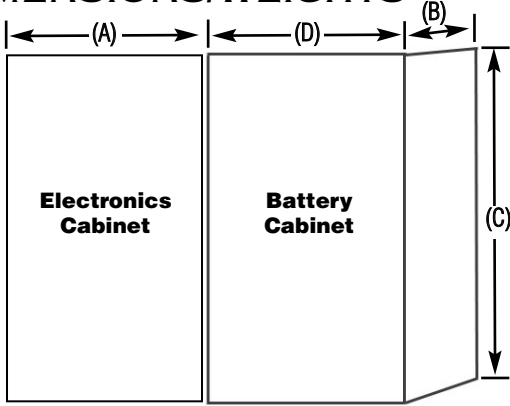

Width (A)	36"
Depth (B)	24"
Height (C)	80"
Width (D)	29"

SYSTEM INPUT/OUTPUT RATINGS

System Rating (kW/kVA)	6.0	
Input Voltage (V) : Input Current (A)	120/240 : 37.4	
	277 : 32.4	
	120/208 : 43.1	
Output Voltage : Output Current*	120/240 : 50.0/25.0	
	277 : 21.7	
	120/208 : 50.0/28.8	
	120/277 : 50.0/21.7	
OCB Pole Spaces Available		
	without trip alarm	20
	with trip alarm	10
Heat Rejection (Btu/hr)	2864	
Weights (Lbs)		
	Electronics	950
	Empty batt cab	350
	90 min battery	1325
	20 min battery**	350



SYSTEM ONE-LINE DIAGRAM

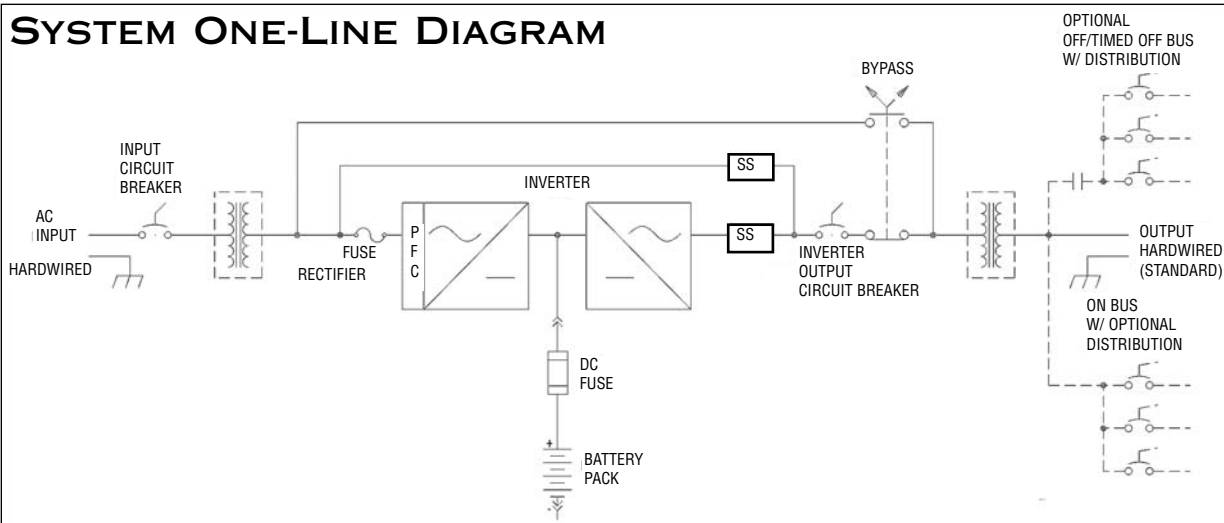

*Multi-voltage total loads not to exceed system rating

**Battery cabinet not required

WARRANTY

Standard Warranty

(Requires execution of factory start-up within 120 days of shipment) Chloride will provide parts and on-site labor for the first 12 months following start-up of the product, and parts only for an additional 12 months. If factory start-up is not executed within 120 days of shipment, Chloride will provide a parts warranty for 12 months from the date of shipment.

Extended Warranty Available

Consult factory for extended warranty and service option

ALL SPECIFICATIONS SUBJECT TO CHANGE WITHOUT NOTICE



CHLORIDE
SYSTEMS

272 West Stag Park Service Road • Burgaw NC 28425
Telephone: (910) 259 1000 • Facsimile: (800) 258 8803
www.chloridesys.com

Synthesis CHT Series for Emergency Lighting Applications, 6,000VA

SUGGESTED SPECIFICATION

Furnish and install Chloride single phase Emergency Lighting System known as Synthesis CHT Series. The system shall be UL listed to Underwriters' Laboratories standard 924.

Equipment and accessories furnished under the terms of this specification shall be the standard product of a single manufacturer and shall be equal in all respects to those supplied by Chloride. Catalog numbers and model designations which appear herein indicate design, quality and the type of material as well as required operating characteristics. All equipment shall be in compliance with the applicable UL standards.

The connected load shall be continuously powered by the filtered power of the double conversion Synthesis CHT System and upon failure of the utility input, the load shall automatically continue to be powered via the Synthesis CHT system's battery and inverter for the specified time. Upon restoration of utility power, the system will automatically resume supplying the load with double conversion, filtered power. The system input power factor shall be corrected to 0.99 or greater.

The Synthesis CHT Series shall be capable of powering any combination of fluorescent ballasted lamps, incandescent lamps, electronic and high power factor compact fluorescent ballasts, HID lamps or other approved loads up to the total rating of the system. The system shall automatically protect itself against damage from overloads and short circuits while powered from either utility AC or during emergency mode operation. It shall automatically recover from such overloads and clear short circuits by means of overcurrent protection devices.

Under emergency operations, the microprocessor shall regulate the output voltage within $\pm 2\%$ of nominal at full load for the specified discharge period; and the frequency shall be within $\pm 0.5\%$ of nominal.

During emergency mode operation, the systems' efficiency shall not be less than 85%. The system shall use redundant fans in the cooling of the electronic compartment. The AC output to the load shall be isolated from the utility input during emergency mode operation.

Under emergency mode conditions, the Synthesis CHT shall be powered by maintenance free, sealed lead calcium batteries. The battery shall operate entirely unattended and require no addition of water for a period of 10 years or longer. Periodic inspection of batteries is recommended.

A low voltage disconnect circuit designed to reduce battery discharge during extended power outages, shall monitor the battery voltage and disconnect the inverter when battery voltage drops to approximately 85% of nominal voltage. Restoration of utility power following a low voltage disconnect event shall automatically re-start the Synthesis CHT System

The Synthesis CHT solid state battery charger shall be completely automatic with a programmed reference, and capable of restoring the battery to capacity within UL 924 requirements. The charger shall have capability to recharge a battery of up to 4 hour discharge capacity and shall automatically maintain the battery in the fully charged condition whenever the utility power is available.

The LCD readout system status panel shall display real time operating parameters of the system as well as the results of the 25 most recent battery test events. The LCD readout shall also display the 25 most recent system alarm events including the date and time of such events. Dry contact for remote failure alarm, and a DB9 computer style connector shall provide volt free contacts for remote alarm indication

UNIT CHECK LIST

Catalog No. _____		VA Rating: <u>6,000</u>	
Battery Type: Sealed Lead Calcium	Operating Time: 90 / 20 / 10 Min.		
Utility Input: _____ VAC; Single Phase			
Output Circuit Breakers:			
Qty: _____	AC Volts: _____	Amps: _____	Normally ON <input type="checkbox"/> Normally OFF <input type="checkbox"/> Trip Alarm YES <input type="checkbox"/> NO <input type="checkbox"/>
Qty: _____	AC Volts: _____	Amps: _____	Normally ON <input type="checkbox"/> Normally OFF <input type="checkbox"/> Trip Alarm YES <input type="checkbox"/> NO <input type="checkbox"/>
Qty: _____	AC Volts: _____	Amps: _____	Normally ON <input type="checkbox"/> Normally OFF <input type="checkbox"/> Trip Alarm YES <input type="checkbox"/> NO <input type="checkbox"/>
Qty: _____	AC Volts: _____	Amps: _____	Normally ON <input type="checkbox"/> Normally OFF <input type="checkbox"/> Trip Alarm YES <input type="checkbox"/> NO <input type="checkbox"/>
REMARKS: _____			

ALL SPECIFICATIONS SUBJECT TO CHANGE WITHOUT NOTICE

